

## DatasheetDirect.com

*Your dedicated source for free downloadable datasheets.*

- Over one million datasheets
- Optimized search function
- Rapid quote option
- Free unlimited downloads

Visit [www.datasheetdirect.com](http://www.datasheetdirect.com) to get your free datasheets.

This datasheet has been downloaded by <http://www.datasheetdirect.com/>



---

## PRELIMINARY DATA SHEET

---

# gm5110/gm5110-H gm5120/gm5120-H XGA/SXGA LCD Controller

\*\*\* Genesis Microchip Confidential \*\*\*

**NOTE:** Sections in this data sheet that mention HDCP apply only to the HDCP-enabled chip versions (gm5110-H and gm5120-H). All other sections apply to all chip versions (gm5110, gm5110-H, gm5120, and gm5120-H).

Publication number: C5110-DAT-01C

Publication date: June 2002

---

### Genesis Microchip Inc.

2150 Gold Street, Alviso, P.O. Box 2150, CA USA 95002 Tel: (408) 262-6599 Fax: (408) 262-6365  
165 Commerce Valley Dr. West, Thornhill, ON Canada L3T 7V8 Tel: (905) 889-5400 Fax: (905) 889-5422  
1096, 12thA Main, Hal II Stage, Indira Nagar, Bangalore-560 008, India, Tel: (91)-80-526-3878, Fax: (91)-80-529-6245  
4F, No. 24, Ln 123, Sec 6, Min-Chuan E. Rd., Taipei, Taiwan, ROC Tel: 886-2-2791-0118 Fax: 886-2-2791-0196  
143-37 Hyundai Tower, #902, Samsung-dong, Kangnam-gu, Seoul, Korea 135-090 Tel 82-2-553-5693 Fax 82-2-552-4942  
Rm2614-2618 Shenzhen Office Tower, 6007 Shennan Blvd, 518040, Shenzhen, Guandong, P.R.C., Tel (0755)386-0101, Fax (0755)386-7874  
2-9-5 Higashigotanda, Shinagawa-ku, Tokyo, 141-0022, Japan, Tel 81-3-5798-2758, Fax 81-3-5798-2759  
[www.genesis-microchip.com](http://www.genesis-microchip.com) / [info@genesis-microchip.com](mailto:info@genesis-microchip.com)

### Revision History

Document	Description	Date
C5110-DAT-01A	<ul style="list-style-type: none"> <li>Initial release</li> </ul>	Aug 2001
C5110-DAT-01B	<ul style="list-style-type: none"> <li>Added note on Front Cover regarding HDCP enabled versions.</li> <li>Added section 4.12 - Energy Spectrum Management (ESM).</li> <li>In section 4.15 clarified that ROM_ADDR[15:0] have internal 60KΩ pull-down resistor.</li> <li>Changes to Table 21– DC Characteristics:               <ul style="list-style-type: none"> <li>Renamed parameters <math>\theta_{JA\_XGA}</math>, <math>\theta_{JA\_SXGA}</math>, <math>\theta_{JC\_XGA}</math> and <math>\theta_{JC\_SXGA}</math> to <math>\theta_{JA\_5110}</math>, <math>\theta_{JA\_5120}</math>, <math>\theta_{JC\_5110}</math> and <math>\theta_{JC\_5120}</math> and revised their values.</li> <li>Added note (4) regarding the maximum case temperature.</li> </ul> </li> <li>Changes to Table 22– Maximum Speed of Operation:               <ul style="list-style-type: none"> <li>Renamed parameters <math>P_{5110}</math> and <math>P_{5120}</math> and revised their values.</li> <li>Renamed parameters <math>I_{5110}</math>, <math>I_{5110\_2.5\_VDD}</math>, etc.</li> <li>Added note (6).</li> </ul> </li> <li>Removed the clock speed column from section 6 - Ordering Information and added the ordering information for gm5110-H and gm5120-H.</li> </ul>	Oct 2001
D5110-DAT-01C	<ul style="list-style-type: none"> <li>Pins 143 ~ 146: changed xxx_SDDS or xxxx_SDDS to xxx_DDDS or xxxx_DDDS respectively</li> <li>Pins 138 ~ 141: changed xxx_DDDS or xxxx_DDDS to xxx_SDDS or xxxx_SDDS respectively</li> <li>Pins 147 ~ 148: changed xxx_DPLL to xxx_RPLL</li> </ul>	June 2002

### Related documents

Chip documents	
C5110-PBR-01	Preliminary Product Brief gm5110
C5120-PBR-01	Preliminary Product Brief gm5120
C5115-APB-01	gm5115 Product Family On-chip Microcontroller (OCM) Firmware Configurations
C5115-APB-02	gm5115 Product Family Support for Standard RGB (sRGB)
C5115-TOP-01	gm5115 Theory of Operation
C5115-DSL-01	gm5115 Register Listing
C5115-DSR-02	gm5115 Input Processing Programming Guide
Reference design documents	
B0108-GUD-01	5110RD1 Reference Design Users Guide
B0108-SCH-01	5110RD1 Reference Design Schematics
B0108-BOM-01	5110RD1 Reference Design Bill of Materials
Firmware / tools documents	
B0092-SWT-01	gm5115 Product Family Firmware Theory of Operation for Full Custom Configuration
B0092-SUG-01	gm5115 Product Family Firmware User Guide for Full-Custom
B0092-PRN-01	gm5115 Product Family Firmware Release Notes for Full-Custom
B0108-SUG-01	gm5115 Product Family Firmware User Guide for Standalone
B0108-PRN-01	gm5115 Product Family Firmware Release Notes for Standalone
S0006-GUD-01	G-Probe Debug Software User Guide
S0014-GUD-01	G-Wizard Software User Guide

Trademarks: RealColor, Real Recovery, and Ultra-Reliable DVI are trademarks of Genesis Microchip Inc.



Genesis Microchip Inc. reserves the right to change or modify the information contained herein without notice. Please obtain the most recent revision of this document. Genesis Microchip Inc. makes no warranty for the use of its products and bears no responsibility for any errors or omissions that may appear in this document.

## Table Of Contents

1. Overview .....	1
1.1 gm5110/20 System Design Example .....	1
1.2 gm5110/20 Features .....	2
2. gm5110/20 Pinout .....	3
3. gm5110/20 Pin List .....	4
4. Functional Description .....	10
4.1 Clock Generation .....	10
4.1.1 Using the Internal Oscillator with External Crystal .....	11
4.1.2 Using an External Clock Oscillator .....	13
4.1.3 Clock Synthesis .....	14
4.2 Hardware Reset .....	16
4.3 Analog to Digital Converter .....	16
4.3.1 ADC Pin Connection .....	17
4.3.2 ADC Characteristics .....	17
4.3.3 Clock Recovery Circuit .....	18
4.3.4 Sampling Phase Adjustment .....	19
4.3.5 ADC Capture Window .....	19
4.4 DVI Receiver Block .....	20
4.4.1 DVI Receiver Characteristics .....	20
4.4.2 DVI Capture Window .....	21
4.4.3 HDCP (High-Bandwidth Digital Content Protection) .....	21
4.5 Test Pattern Generator (TPG) .....	21
4.6 Input Format Measurement .....	22
4.6.1 HSYNC / VSYNC Delay .....	22
4.6.2 Horizontal and Vertical Measurement .....	23
4.6.3 Format Change Detection .....	23
4.6.4 Watchdog .....	24
4.6.5 Internal Odd/Even Field Detection (For Interlaced Inputs to ADC Only) .....	24
4.6.6 Input Pixel Measurement .....	24
4.6.7 Image Phase Measurement .....	24
4.6.8 Image Boundary Detection .....	25
4.6.9 Image Auto Balance .....	25
4.7 RealColor™ Digital Color Controls .....	25
4.7.1 RealColor™ Flesh tone Adjustment .....	25
4.7.2 Color Standardization and sRGB Support .....	26
4.8 High-Quality Scaling .....	26
4.8.1 Variable Zoom Scaling .....	26

4.8.2 Horizontal and Vertical Shrink .....	26
4.8.3 Moiré Cancellation .....	27
4.9 Bypass Options .....	27
4.10 Gamma LUT .....	27
4.11 Display Output Interface .....	27
4.11.1 Display Synchronization .....	27
4.11.2 Programming the Display Timing .....	28
4.11.3 Panel Power Sequencing (PPWR, PBIAS) .....	29
4.11.4 Output Dithering .....	30
4.12 Energy Spectrum Management (ESM) .....	30
4.13 OSD .....	30
4.13.1 On-Chip OSD SRAM .....	31
4.13.2 Color Look-up Table (LUT) .....	32
4.14 On-Chip Microcontroller (OCM) .....	32
4.14.1 Standalone Configuration .....	33
4.14.2 Full-Custom Configuration .....	34
4.14.3 General Purpose Inputs and Outputs (GPIO's) .....	35
4.15 Bootstrap Configuration Pins .....	35
4.16 Host Interface .....	36
4.16.1 Host Interface Command Format .....	37
4.16.2 2-wire Serial Protocol .....	37
4.17 Miscellaneous Functions .....	39
4.17.1 Low Power State .....	39
4.17.2 Pulse Width Modulation (PWM) Back Light Control .....	39
5. Electrical Specifications .....	40
5.1 Preliminary DC Characteristics .....	40
5.2 Preliminary AC Characteristics .....	41
6. Ordering Information .....	43
7. Mechanical Specifications .....	44

## List Of Tables

Table 1.	Analog Input Port.....	4
Table 2.	DVI Input Port .....	5
Table 3.	RCLK PLL Pins.....	5
Table 4.	Analog HSYNC/VSYNC Inputs.....	6
Table 5.	System Interface and GPIO Signals.....	6
Table 6.	Display Output Port .....	7
Table 7.	Parallel ROM Interface Port .....	8
Table 8.	Reserved Pins.....	8
Table 9.	Power Pins for ADC Sampling Clock DDS .....	9
Table 10.	Power Pins for Display Clock DDS.....	9
Table 11.	I/O Power and Ground Pins .....	9
Table 12.	Core Power and Ground Pins.....	9
Table 13.	TCLK Specification .....	14
Table 14.	Pin Connection for RGB Input with HSYNC/VSYNC .....	17
Table 15.	ADC Characteristics .....	18
Table 16.	DVI Receiver Characteristics .....	20
Table 17.	gm5110/20 GPIOs and Alternate Functions.....	35
Table 18.	Bootstrap Signals .....	36
Table 19.	Instruction Byte Map .....	37
Table 20.	Absolute Maximum Ratings .....	40
Table 21.	DC Characteristics .....	41
Table 22.	Maximum Speed of Operation.....	42
Table 23.	Display Timing and DCLK Adjustments .....	42
Table 24.	2-Wire Host Interface Port Timing.....	42

## List Of Figures

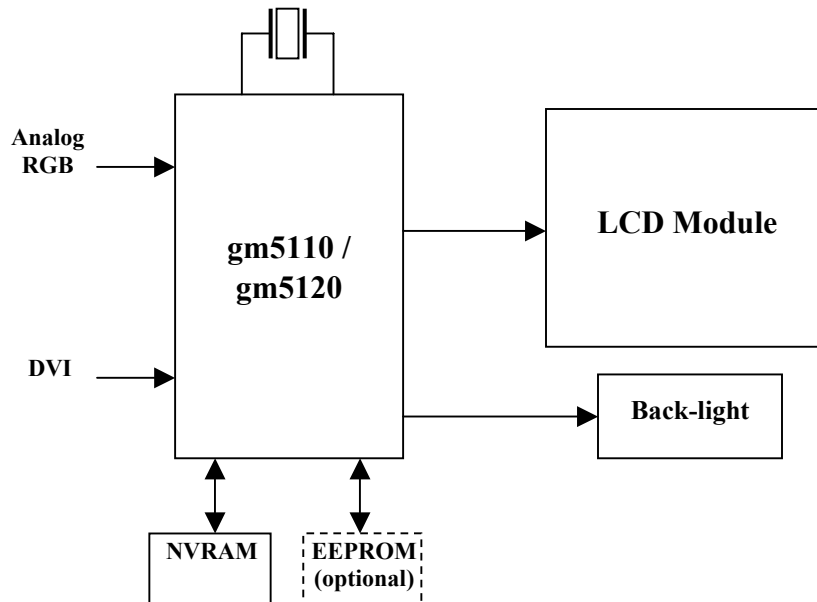
Figure 1.	gm5110/20 System Design Example .....	1
Figure 2.	gm5110/20 Pin Out Diagram .....	3
Figure 3.	gm5110/20 Functional Block Diagram.....	10
Figure 4.	Using the Internal Oscillator with External Crystal.....	11
Figure 5.	Internal Oscillator Output .....	12
Figure 6.	Sources of Parasitic Capacitance .....	13
Figure 7.	Using an External Single-ended Clock Oscillator .....	14
Figure 8.	Internally Synthesized Clocks.....	15
Figure 9.	On-chip Clock Domains .....	16
Figure 10.	Example ADC Signal Terminations.....	17
Figure 11.	gm5110/20 Clock Recovery .....	18
Figure 12.	ADC Capture Window .....	19
Figure 13.	Some of gm5110/20 built-in test patterns .....	21
Figure 14.	HSYNC Delay.....	22
Figure 15.	Active Data Crosses HSYNC Boundary .....	23
Figure 16.	ODD/EVEN Field Detection.....	24
Figure 17.	RealColor™ Digital Color Controls.....	25
Figure 18.	Display Windows and Timing.....	28
Figure 19.	Single Pixel Width Display Data.....	29
Figure 20.	Double Pixel Wide Display Data .....	29
Figure 21.	Panel Power Sequencing .....	29
Figure 22.	OSD Cell Map.....	31
Figure 23.	OCM Full-Custom and Standalone Configurations .....	32
Figure 24.	Programming OCM in Standalone Configuration.....	33
Figure 25.	Programming the OCM in Full-Custom Configuration .....	34
Figure 26.	Factory Calibration and Test Environment .....	36
Figure 27.	2-Wire Protocol Data Transfer .....	38
Figure 28.	2-Wire Write Operations (0x1x and 0x2x).....	38
Figure 29.	2-Wire Read Operation (0x9x and 0xAx) .....	39
Figure 30.	gm5110/gm5120 208-pin PQFP Mechanical Drawing .....	44

# 1. OVERVIEW

The gm5110/20 is a graphics processing IC for Liquid Crystal Display (LCD) monitors at XGA/SXGA resolution. It provides all key IC functions required for the highest quality LCD monitors. On-chip functions include a high-speed triple-ADC and PLL, Ultra-Reliable DVI™ receiver, a high quality zoom and shrink scaling engine, an on-screen display (OSD) controller, digital color controls and an on-chip microcontroller (OCM). With this level of integration, the gm5110/20 devices simplify and reduce the cost of LCD monitors while maintaining a high-degree of flexibility and quality.

## 1.1 gm5110/20 System Design Example

Figure 1 below shows a typical dual interface LCD monitor system based on the gm5110/20. Designs based on the gm5110/20 have reduced system cost, simplified hardware and firmware design and increased reliability because only a minimal number of components are required in the system.



**Figure 1. gm5110/20 System Design Example**

## 1.2 gm5110/20 Features

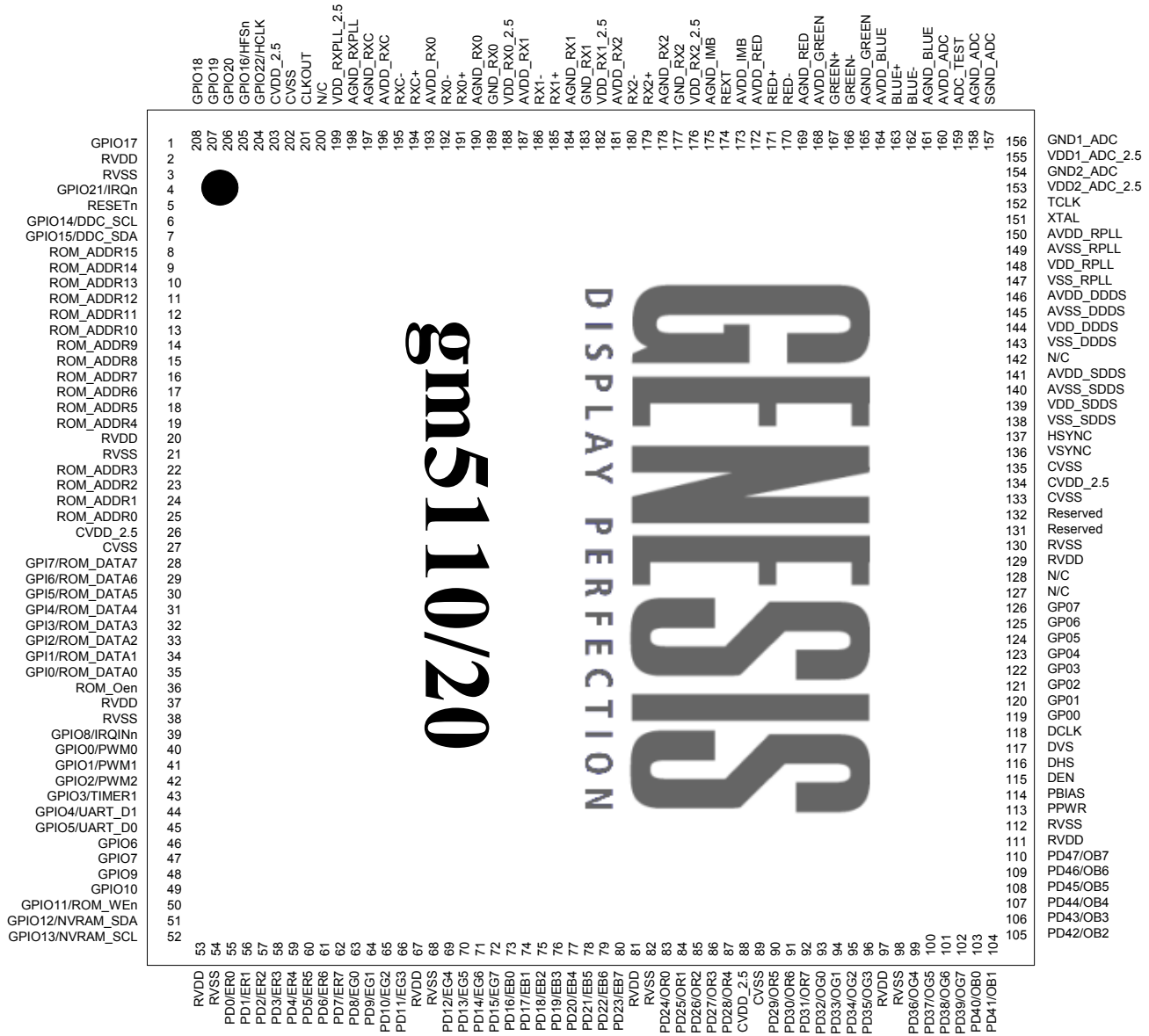
### FEATURES

- Zoom (from VGA) and shrink (from UXGA) scaling
- Integrated 8-bit triple-channel ADC / PLL
- Integrated Ultra-Reliable DVI™ 1.0-compliant receiver
- High-Bandwidth Digital Content Protection (HDCP)
- Embedded microcontroller with parallel ROM interface
- On-chip versatile OSD engine
- All system clocks synthesized from a single external crystal
- Programmable gamma correction (CLUT)
- RealColor controls provide sRGB compliance
- PWM back light intensity control
- 5-Volt tolerant inputs
- Low EMI and power saving features
- **High-Quality Advanced Scaling**
  - Fully programmable zoom ratios
  - High-quality shrink capability from UXGA resolution
  - Real Recovery™ function provides full color recovery image for refresh rates higher than those supported by the LCD panel
  - Moire cancellation
- **Analog RGB Input Port**
  - Supports up to 162MHz (SXGA 75Hz / UXGA 60Hz)
  - On-chip high-performance PLLs (only a single reference crystal required)
- **Auto-Configuration / Auto-Detection**
  - Input format detection
  - Phase and image positioning
- **Ultra-Reliable DVI Compliant Input Port**
  - Operating up to 165 MHz (up to UXGA 60Hz)
  - Direct connect to all DVI compliant digital transmitters
  - High-bandwidth Digital Content Protection (HDCP)
- **RealColor™ Technology**
  - Digital brightness and contrast controls
  - TV color controls including hue and saturation controls
  - Flesh-tone adjustment
  - Full color matrix allows end-users to experience the same colors as viewed on CRTs and other displays (e.g. sRGB compliance)
- **On-chip OSD Controller**
  - On-chip RAM for downloadable menus
  - 1, 2 and 4-bit per pixel character cells
  - Horizontal and vertical stretch of OSD menus
  - Blinking, transparency and blending
- **On-chip Microcontroller**
  - Requires no external micro-controller
  - External parallel ROM interface allows firmware customization with little additional cost
  - 21 general-purpose inputs/outputs (GPIO's) available for managing system devices (keypad, back-light, NVRAM, etc)
  - Industry-standard firmware embedded on-chip, requires no external ROM (configuration settings stored in NVRAM)
- **Programmable Output Format**
  - Single / double wide up to XGA 75Hz output for gm5110 and up to SXGA 75Hz output for gm5120
  - Pin swap, odd / even swap and red / blue group swap of RGB outputs for flexibility in board layout
  - Support for 8 or 6-bit panels (with high-quality dithering)
- **Highly Integrated System-on-a-Chip Reduces Component Count for *Highly Cost Effective Solution***
- ***Stand-alone* operation requires no external ROM and no firmware development for *Fast Time to Market***
- **Pin and register compatible *Family of Products*:**
  - gm5110/gm5120 Dual-Interface XGA/SXGA
  - gm3110/gm3120 Digital-Interface XGA/SXGA
  - gm2110/gm2120 Analog-Interface XGA/SXGA

## 2. GM5110/20 PINOUT

gm5110 and gm5120 are pin-compatible. These devices are available in a 208-pin Plastic Quad Flat Pack (PQFP) package. Figure 2 provides the pin locations for all signals.

**Figure 2. gm5110/20 Pin Out Diagram**



### 3. GM5110/20 PIN LIST

I/O Legend: **A** = Analog, **I** = Input, **O** = Output, **P** = Power, **G**= Ground

**Table 1. Analog Input Port**

Pin Name	No.	I/O	Description
AVDD_RED	172	AP	Analog power (3.3V) for the red channel. Must be bypassed with decoupling capacitor to AGND_RED pin on system board (as close as possible to the pin).
RED+	171	AI	Positive analog input for Red channel.
RED-	170	AI	Negative analog input for Red channel.
AGND_RED	169	AG	Analog ground for the red channel. Must be directly connected to the analog system ground plane.
AVDD_GREEN	168	AP	Analog power (3.3V) for the green channel. Must be bypassed with decoupling capacitor to AGND_GREEN pin on system board (as close as possible to the pin).
GREEN+	167	AI	Positive analog input for Green channel.
GREEN-	166	AI	Negative analog input for Green channel.
AGND_GREEN	165	AG	Analog ground for the green channel. Must be directly connected to the analog system ground plane.
AVDD_BLUE	164	AP	Analog power (3.3V) for the blue channel. Must be bypassed with decoupling capacitor to AGND_BLUE pin on system board (as close as possible to the pin).
BLUE+	163	AI	Positive analog input for Blue channel.
BLUE-	162	AI	Negative analog input for Blue channel.
AGND_BLUE	161	AG	Analog ground for the blue channel. Must be directly connected to the analog system ground plane.
AVDD_ADC	160	AP	Analog power (3.3V) for ADC analog blocks that are shared by all three channels. Includes band gap reference, master biasing and full-scale adjust. Must be bypassed with decoupling capacitor to AGND_ADC pin on system board (as close as possible to the pin).
ADC_TEST	159	AO	Analog test output for ADC Do not connect.
AGND_ADC	158	AG	Analog ground for ADC analog blocks that are shared by all three channels. Includes band gap reference, master biasing and full-scale adjust. Must be directly connected to analog system ground plane.
SGND_ADC	157	AG	Dedicated pad for substrate guard ring that protects the ADC reference system. Must be directly connected to the analog system ground plane.
GND1_ADC	156	G	Digital GND for ADC clocking circuit. Must be directly connected to the digital system ground plane
VDD1_ADC_2.5	155	P	Digital power (2.5V) for ADC encoding logic. Must be bypassed with decoupling capacitor to GND1_ADC pin on system board (as close as possible to the pin).
GND2_ADC	154	G	Digital GND for ADC clocking circuit. Must be directly connected to the digital system ground plane.
VDD2_ADC_2.5	153	P	Digital power (2.5V) for ADC encoding logic. Must be bypassed with decoupling capacitor to GND2_ADC pin on system board (as close as possible to the pin).

**Table 2. DVI Input Port**

Pin Name	No	I/O	Description
AVDD_IMB	173	AP	Analog VDD (3.3V) for internal biasing circuits. Must be bypassed with decoupling capacitors (as close as possible to the pin).
REXT	174	AI	External reference resistor. An external 1Kohm (1%) resistor should be connected from this pin to AVDD_IMB pin.
AGND_IMB	175	AG	Analog GND for internal biasing circuits. Must be connected directly to the ground plane.
VDD_RX2_2.5	176	P	VDD (2.5V) for DVI input pair 2 logic circuits. Must be bypassed with decoupling capacitor to GND_RX2 pin (as close as possible to the pin).
GND_RX2	177	G	GND for DVI input pair 2 logic circuits. Must be connected directly to the ground plane.
AGND_RX2	178	AG	Analog GND for DVI input pair 2 input buffer. Must be connected directly to the analog ground plane.
RX2+	179	AI	DVI input pair 2
RX2-	180	AI	DVI input pair 2
AVDD_RX2	181	AP	Analog VDD (3.3V) for DVI input pair 2 input buffer. Must be bypassed with decoupling capacitor to AGND_RX2 pin (as close as possible to the pin).
VDD_RX1_2.5	182	P	VDD (2.5V) for DVI input pair 1 logic circuits. Must be bypassed with decoupling capacitor to GND_RX1 pin (as close as possible to the pin).
GND_RX1	183	G	GND for DVI input pair 1 input buffer. Must be connected directly to the analog ground plane.
AGND_RX1	184	AG	Analog GND for DVI input pair 1 input buffer. Must be connected directly to the analog ground plane.
RX1+	185	AI	DVI input pair 1
RX1-	186	AI	DVI input pair 1
AVDD_RX1	187	AP	Analog VDD (3.3V) for DVI input pair 1 input buffer. Must be bypassed with decoupling capacitor to AGND_RX1 pin (as close as possible to the pin).
VDD_RX0_2.5	188	P	VDD (2.5V) for DVI input pair 0 logic circuits. Must be bypassed with decoupling capacitor to GND_RX0 pin (as close as possible to the pin).
GND_RX0	189	G	GND for DVI input pair 0 logic circuits. Must be connected directly to the ground plane.
AGND_RX0	190	AG	Analog GND for DVI input pair 0 input buffer. Must be connected directly to the analog ground plane.
RX0+	191	AI	DVI input pair 0
RX0-	192	AI	DVI input pair 0
AVDD_RX0	193	AP	Analog VDD (3.3V) for DVI input pair 0 input buffer. Must be bypassed with decoupling capacitor to AGND_RX0 pin (as close as possible to the pin).
RXC+	194	AI	DVI input clock pair
RXC-	195	AI	DVI input clock pair
AVDD_RXC	196	AP	Analog VDD (3.3V) for DVI input clock pair input buffer. Must be bypassed with 100pF capacitor to AGND_RXC pin (as close as possible to the pin).
AGND_RXC	197	AG	Analog GND for DVI input clock pair input buffer. Must be connected directly to the analog ground plane.
GND_RXPLL	198	G	Digital GND for the DVI receiver internal PLL. Must be connected directly to the system ground plane.
VDD_RXPLL_2.5	199	AP	Analog VDD (2.5V) for the DVI receiver internal PLL. Must be bypassed with a decoupling capacitor to AGND_RXPLL pin (as close as possible to the pin).
CLKOUT	201	AO	For test purposes only. Do not connect.

**Table 3. RCLK PLL Pins**

Pin Name	No	I/O	Description
AVDD_RPLL	150	AP	Analog power for the Reference DDS PLL. Connect to 3.3V supply. Must be bypassed with a 0.1uF capacitor to pin AVSS_RPLL (as close to the pin as possible).
AVSS_RPLL	149	AG	Analog ground for the Reference DDS PLL. Must be directly connected to the analog system ground plane.
TCLK	152	AI	Reference clock (TCLK) from the 14.3MHz crystal oscillator, or from single-ended CMOS/TTL clock oscillator (refer to Figure 7). This is a 5V-tolerant input.
XTAL	151	AO	Crystal oscillator output.
VDD_RPLL	148	P	Digital power for RCLK PLL. Connect to 3.3V supply.
VSS_RPLL	147	G	Digital ground for RCLK PLL.

**Table 4. Analog HSYNC/VSYNC Inputs**

Pin Name	No	I/O	Description
HSYNC	137	I	ADC input horizontal sync input. [Input, Schmitt trigger (400mV typical hysteresis), 5V-tolerant]
VSYNC	136	I	ADC input vertical sync input. [Input, Schmitt trigger (400mV typical hysteresis), 5V-tolerant]

**Table 5. System Interface and GPIO Signals**

Pin Name	No	I/O	Description
RESETn	5	I	Active-low hardware reset signal. The reset signal must be held low for at least 1 $\mu$ S. [Input, Schmitt trigger (400mV typical hysteresis), 5V-tolerant]
GPIO0/PWM0	40	IO	General-purpose input/output signal or PWM0. Open drain option via register setting. [Bi-directional, Schmitt trigger (400mV typical hysteresis), 5V-tolerant]
GPIO1/PWM1	41	IO	General-purpose input/output signal or PWM1. Open drain option via register setting. [Bi-directional, Schmitt trigger (400mV typical hysteresis), 5V-tolerant]
GPIO2/PWM2	42	IO	General-purpose input/output signal or PWM2. Open drain option via register setting. [Bi-directional, Schmitt trigger (400mV typical hysteresis), 5V-tolerant]
GPIO3/TIMER1	43	IO	General-purpose input/output signal. Open drain option via register setting. This pin is also connected to Timer 1 clock input of the OCM. [Bi-directional, Schmitt trigger (400mV typical hysteresis), 5V-tolerant]
GPIO4/UART_DI	44	IO	General-purpose input/output signal. Open drain option via register setting. This pin is also connected to the OCM UART data input signal by programming an OCM register. [Bi-directional, Schmitt trigger (400mV typical hysteresis), 5V-tolerant]
GPIO5/UART_DO	45	IO	General-purpose input/output signal. Open drain option via register setting. This pin is also connected to the OCM UART data output signal by programming an OCM register. [Bi-directional, Schmitt trigger (400mV typical hysteresis), 5V-tolerant]
GPIO6	46	IO	General-purpose input/output signal. [Bi-directional, Schmitt trigger (400mV typical hysteresis), 5V-tolerant]
GPIO7	47	IO	General-purpose input/output signal. [Bi-directional, Schmitt trigger (400mV typical hysteresis), 5V-tolerant]
GPIO8/IRQIn	39	IO	General-purpose input/output signal. This is also active-low interrupt input to OCM and is directly wired to OCM int_0n. [Bi-directional, Schmitt trigger (400mV typical hysteresis), 5V-tolerant]
GPIO9	48	IO	General-purpose input/output signal. Open drain option via register setting. [Bi-directional, Schmitt trigger (400mV typical hysteresis), 5V-tolerant]
GPIO10	49	IO	General-purpose input/output signal. Open drain option via register setting. [Bi-directional, Schmitt trigger (400mV typical hysteresis), 5V-tolerant]
GPIO11/ROM_WEn	50	IO	General-purpose input/output or PROM write enable signal. Open drain option via register setting. [Bi-directional Input, Schmitt trigger (400mV typical hysteresis), 5V-tolerant]
GPIO12/NVRAM_SDA	51	IO	General-purpose input/output or master 2-wire serial interface to NVRAM in standalone operation. Open drain option via register setting. [Bi-directional Input, Schmitt trigger (400mV typical hysteresis), 5V-tolerant]
GPIO13/NVRAM_SCL	52	IO	
GPIO14/DDC_SCL	6	I	DDC Interface for DVI-HDCP communication. This is 5V-tolerant SCL pin.
GPIO15/DDC_SDA	7	IO	DDC Interface for DVI-HDCP communication. This is 5V-tolerant SDA pin.
GPIO16/HFSn	205	IO	General-purpose input/output signal when host interface is disabled, or host interface framing signal. [Bi-directional, Schmitt trigger (400mV typical hysteresis), slew rate limited, 5V tolerant]
GPIO17	1	IO	General-purpose input/output signal. [Bi-directional, Schmitt trigger (400mV typical hysteresis), 5V-tolerant]
GPIO18	208	IO	
GPIO19	207	IO	
GPIO20	206	IO	
GPIO21/IRQn	4	IO	General-purpose input/output signal when host port is disabled, or active-low and open-drain interrupt output pin. [Bi-directional, 5V-tolerant]
GPIO22/HCLK	204	IO	General-purpose input/output signal when host interface is disabled, or host clock signal. [Bi-directional, Schmitt trigger (400mV typical hysteresis), 5V-tolerant]
GPO0	119	O	General-purpose output signals.
GPO1	120	O	
GPO2	121	O	
GPO3	122	O	
GPO4	123	O	
GPO5	124	O	
GPO6	125	O	
GPO7	126	O	

**Table 6. Display Output Port**

Pin Name	No	I/O	Description
DCLK	118	O	Panel output clock. [Tri-state output, Programmable Drive]
DVS	117	O	Panel Vertical Sync. [Tri-state output, Programmable Drive]
DHS	116	O	Panel Horizontal Sync. [Tri-state output, Programmable Drive]
DEN	115	O	Panel Display Enable, which frames the output background. [Tri-state output, Programmable Drive]
PBIAS	114	O	Panel Bias Control (back light enable) [Tri-state output, Programmable Drive]
PPWR	113	O	Panel Power Control [Tri-state output, Programmable Drive]
PD47	110	O	Panel output data. [Tri-state output, Programmable Drive]
PD46	109	O	
PD45	108	O	
PD44	107	O	
PD43	106	O	
PD42	105	O	
PD41	104	O	
PD40	103	O	
PD39	102	O	
PD38	101	O	
PD37	100	O	
PD36	99	O	
PD35	96	O	
PD34	95	O	
PD33	94	O	
PD32	93	O	
PD31	92	O	
PD30	91	O	
PD29	90	O	
PD28	87	O	
PD27	86	O	
PD26	85	O	
PD25	84	O	
PD24	83	O	
PD23	80	O	
PD22	79	O	
PD21	78	O	
PD20	77	O	
PD19	76	O	
PD18	75	O	
PD17	74	O	
PD16	73	O	
PD15	72	O	
PD14	71	O	
PD13	70	O	
PD12	69	O	
PD11	66	O	
PD10	65	O	
PD9	64	O	
PD8	63	O	
PD7	62	O	
PD6	61	O	
PD5	60	O	
PD4	59	O	
PD3	58	O	
PD2	57	O	
PD1	56	O	
PD0	55	O	

**Table 7. Parallel ROM Interface Port**

Pin Name	No	I/O	Description
ROM_ADDR15	8	IO	ROM address output. These pins also serve as 5V-tolerant bootstrap inputs on power up.
ROM_ADDR14	9	IO	
ROM_ADDR13	10	IO	
ROM_ADDR12	11	IO	
ROM_ADDR11	12	IO	
ROM_ADDR10	13	IO	
ROM_ADDR9	14	IO	
ROM_ADDR8	15	IO	
ROM_ADDR7	16	IO	
ROM_ADDR6	17	IO	
ROM_ADDR5	18	IO	
ROM_ADDR4	19	IO	
ROM_ADDR3	22	IO	
ROM_ADDR2	23	IO	
ROM_ADDR1	24	IO	
ROM_ADDR0	25	IO	
GPI7/ROM_DATA7	28	I	5V-tolerant external PROM data input, or general-purpose input in standalone operation.
GPI6/ROM_DATA6	29	I	
GPI5/ROM_DATA5	30	I	
GPI4/ROM_DATA4	31	I	
GPI3/ROM_DATA3	32	I	
GPI2/ROM_DATA2	33	I	
GPI1/ROM_DATA1	34	I	
GPI0/ROM_DATA0	35	I	
ROM_OEn	36	O	External PROM data Output Enable

**Table 8. Reserved Pins**

Pin Name	No	I/O	Description
N/C	127	O	No connect.
N/C	128	O	No connect.
Reserved	131	I	Tie to GND.
Reserved	132	I	Tie to GND.
N/C	142	O	No connect.
N/C	200	O	No connect.

Note that VDD pins having "\_2.5" in their names should be connected to 2.5V power supplies. All other VDD pins should be connected to 3.3V power supplies.

**Table 9. Power Pins for ADC Sampling Clock DDS**

Pin Name	No	I/O	Description
AVDD_DDDS	146	AP	Analog power for the Destination DDS. Connect to 3.3V supply. Must be bypassed with a 0.1uF capacitor to AVSS_DDDS pin (as close to the pin as possible).
AVSS_DDDS	145	AG	Analog ground for the Destination DDS. Must be directly connected to the analog system ground.
VDD_DDDS	144	P	Digital power for the Destination DDS. Connect to 3.3V supply.
VSS_DDDS	143	G	Digital ground for the Destination DDS.

**Table 10. Power Pins for Display Clock DDS**

Pin Name	No	I/O	Description
AVDD_SDDS	141	AP	Analog power for Source DDS. Connect to 3.3V supply. Must be bypassed with a 0.1uF capacitor to AVSS_SDDS pin (as close to the pin as possible).
AVSS_SDDS	140	AG	Analog ground for Source DDS. Must be directly connected to the analog system ground plane.
VDD_SDDS	139	P	Digital power for the Source DDS. Connect to 3.3V supply.
VSS_SDDS	138	G	Digital ground for the Source DDS.

**Table 11. I/O Power and Ground Pins**

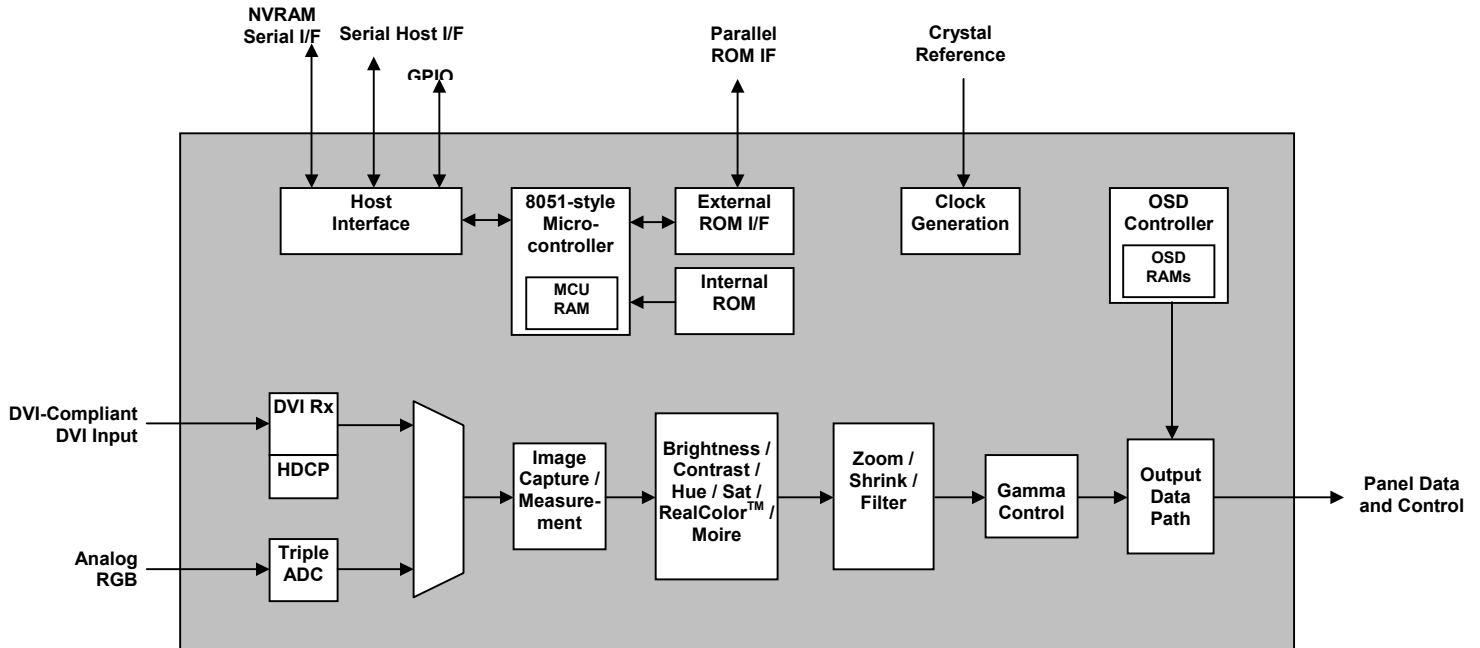
Pin Name	No	I/O	Description
RVDD	2	P	Connect to 3.3V supply. Must be bypassed with a 0.1uF capacitor to RVSS (as close to the pin as possible).
	20	P	
	37	P	
	53	P	
	67	P	
	81	P	
	97	P	
	111	P	
	129	P	
RVSS	3	G	Connect to digital ground.
	21	G	
	38	G	
	54	G	
	68	G	
	82	G	
	98	G	
	112	G	
	130	G	

**Table 12. Core Power and Ground Pins**

Pin Name	No	I/O	Description
CVDD_2.5	26	P	Connect to 2.5V supply. Must be bypassed with a 0.1uF capacitor to CVSS (as close to the pin as possible).
	88	P	
	134	P	
	203	P	
CVSS	27	G	Connect to digital ground.
	89	G	
	133	G	
	135	G	
	202	G	

## 4. FUNCTIONAL DESCRIPTION

A functional block diagram is illustrated below. Each of the functional units shown is described in the following sections.



**Figure 3. gm5110/20 Functional Block Diagram**

### 4.1 Clock Generation

The gm5110/20 features three clock inputs. All additional clocks are internal clocks derived from one or more of these:

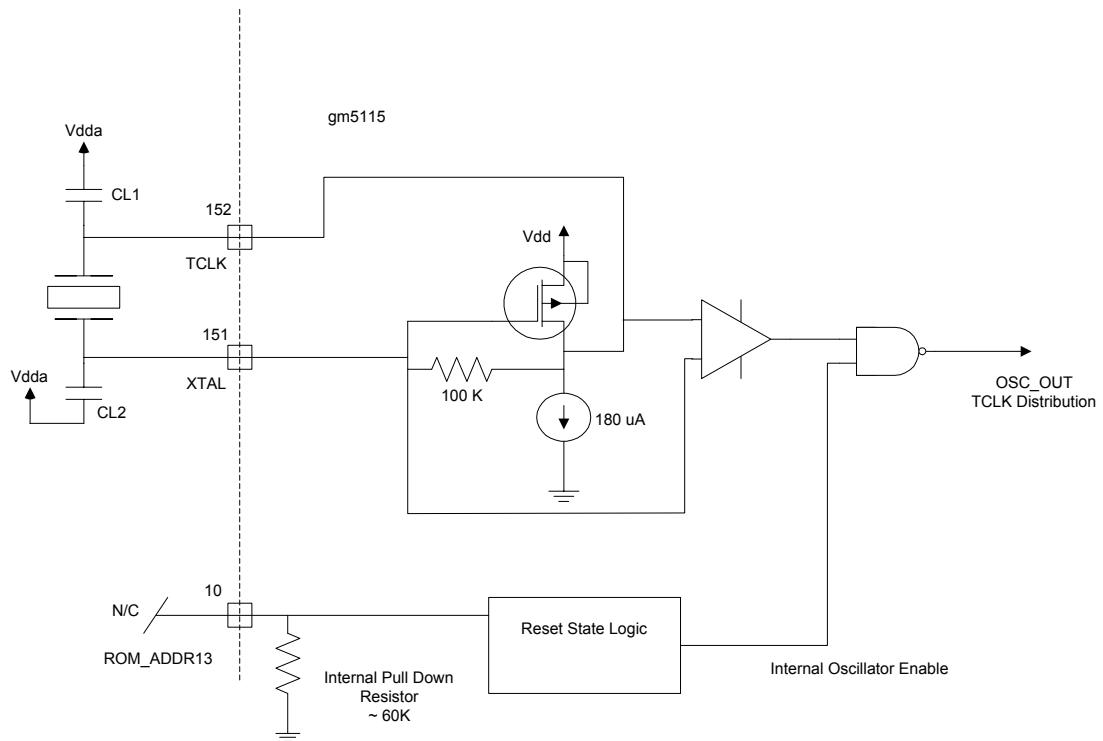
1. Crystal Input Clock (TCLK and XTAL). This is the input pair to an internal crystal oscillator and corresponding logic. A 14.3 MHz TV crystal is recommended. Other crystal frequencies may be used, but require custom programming. This is illustrated in Figure 4 below. Alternatively, a single-ended TTL/CMOS clock oscillator can be driven into the TCLK pin (leave XTAL as N/C in this case). This is illustrated in Figure 7 below. This option is selected by connecting a 10K $\Omega$  pull-up to ROM\_ADDR13 (refer to Table 18). See also Table 14.
2. DVI Differential Input Clock (RC+ and RC-)
3. Host Interface Transfer Clock (HCLK)

The gm5110/20 TCLK oscillator circuitry is a custom designed circuit to support the use of an external oscillator or a crystal resonator to generate a reference frequency source for the gm5110/20 device.

**4.1.1 Using the Internal Oscillator with External Crystal**

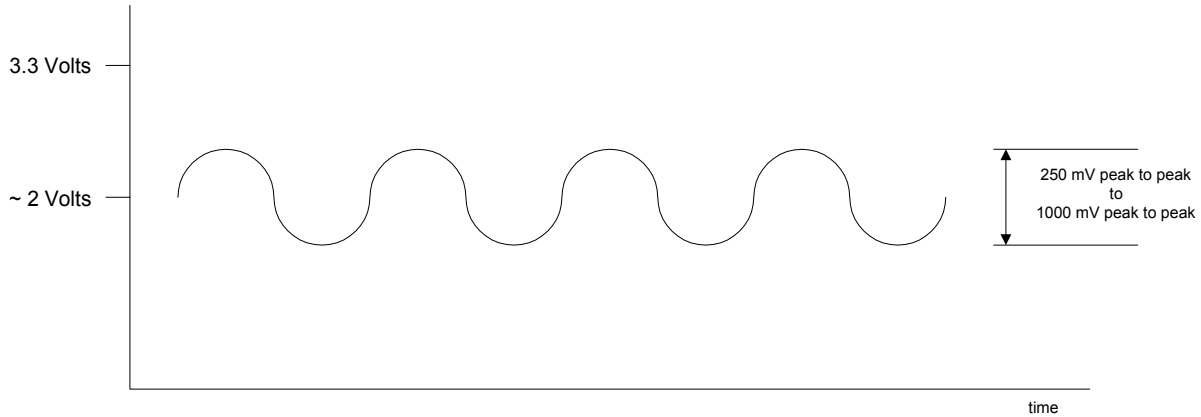
The first option for providing a clock reference is to use the internal oscillator with an external crystal. The oscillator circuit is designed to provide a very low jitter and very low harmonic clock to the internal circuitry of the gm5110/20. An Automatic Gain Control (AGC) is used to insure startup and operation over a wide range of conditions. The oscillator circuit also minimizes the overdrive of the crystal, which reduces the aging of the crystal.

When the gm5110/20 is in reset, the state of the ROM\_ADDR13 pin (pin number 10) is sampled. If the pin is left unconnected (internal pull-down) then internal oscillator is enabled. In this mode a crystal resonator is connected between TCLK (pin 152) and the XTAL (pin 151) with the appropriately sized loading capacitors  $C_{L1}$  and  $C_{L2}$ . The size of  $C_{L1}$  and  $C_{L2}$  are determined from the crystal manufacturer’s specification and by compensating for the parasitic capacitance of the gm5110/20 device and the printed circuit board traces. The loading capacitors are terminated to the analog VDD power supply. This connection increases the power supply rejection ratio when compared to terminating the loading capacitors to ground.



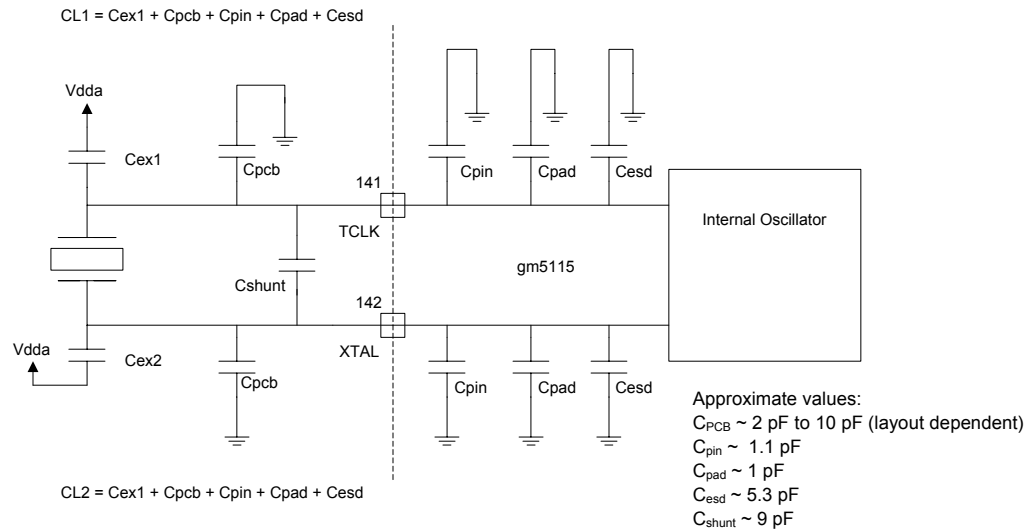
**Figure 4. Using the Internal Oscillator with External Crystal**

The TCLK oscillator uses a Pierce Oscillator circuit. The output of the oscillator circuit, measured at the TCLK pin, is an approximate sine wave with a bias of about 2 volts above ground (see Figure 5). The peak-to-peak voltage of the output can range from 250 mV to 1000 mV depending on the specific characteristics of the crystal and variation in the oscillator characteristics. The output of the oscillator is connected to a comparator that converts the sine wave to a square wave. The comparator requires a minimum signal level of about 50-mV peak to peak to function correctly. The output of the comparator is buffered and then distributed to the gm5110/20 circuits.



**Figure 5. Internal Oscillator Output**

One of the design parameters that must be given some consideration is the value of the loading capacitors used with the crystal as shown in Figure 6. The loading capacitance ( $C_{load}$ ) on the crystal is the combination of  $C_{L1}$  and  $C_{L2}$  and is calculated by  $C_{load} = ((C_{L1} * C_{L2}) / (C_{L1} + C_{L2})) + C_{shunt}$ . The shunt capacitance  $C_{shunt}$  is the effective capacitance between the XTAL and TCLK pins. For the gm5110/20 this is approximately 9 pF.  $C_{L1}$  and  $C_{L2}$  are a parallel combination of the external loading capacitors ( $C_{ex}$ ), the PCB board capacitance ( $C_{pcb}$ ), the pin capacitance ( $C_{pin}$ ), the pad capacitance ( $C_{pad}$ ), and the ESD protection capacitance ( $C_{esd}$ ). The capacitances are symmetrical so that  $C_{L1} = C_{L2} = C_{ex} + C_{PCB} + C_{pin} + C_{pad} + C_{ESD}$ . The correct value of  $C_{ex}$  must be calculated based on the values of the load capacitances. Approximate values are provided in Figure 6.

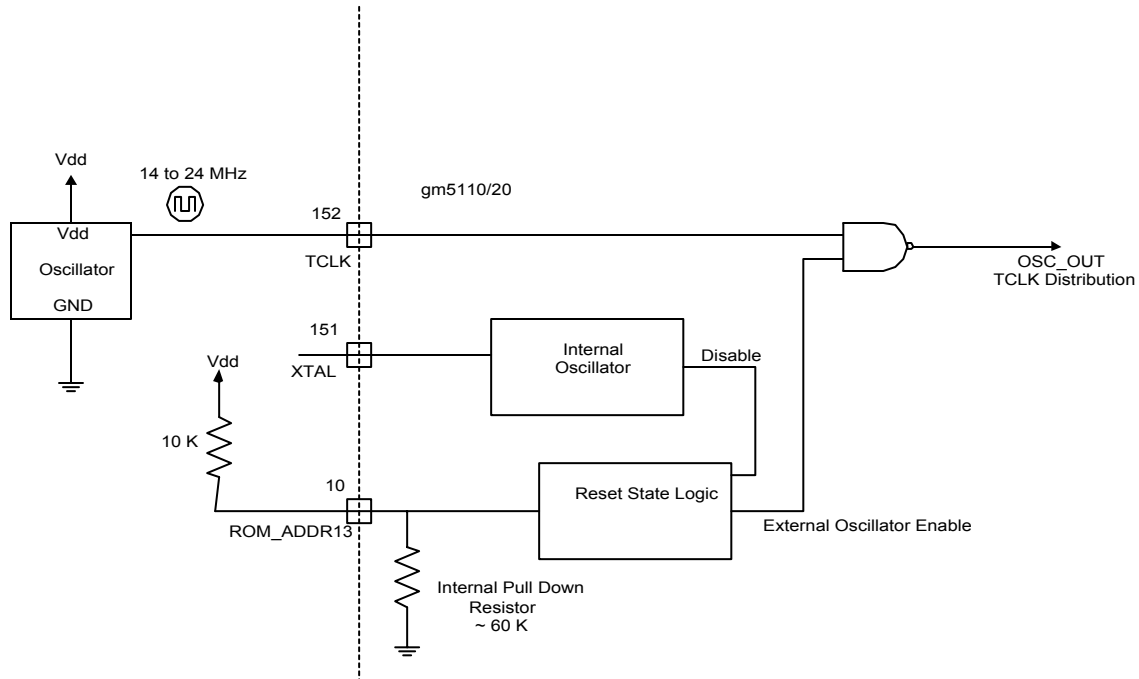


**Figure 6. Sources of Parasitic Capacitance**

Some attention must be given to the details of the oscillator circuit when used with a crystal resonator. The PCB traces should be as short as possible. The value of  $C_{load}$  that is specified by the manufacturer should not be exceeded because of potential start up problems with the oscillator. Additionally, the crystal should be a parallel resonate-cut and the value of the equivalent series resistance must be less than 90 Ohms.

#### 4.1.2 Using an External Clock Oscillator

Another option for providing the reference clock is to use a single-ended external clock oscillator. When the gm5110/20 is in reset, the state of the ROM\_ADDR13 (pin 10) is sampled. If ROM\_ADDR13 is pulled high by connecting to VDD through a pull-up resistor (15KΩ recommended, 15KΩ maximum) then external oscillator mode is enabled. In this mode the internal oscillator circuit is disabled and the external oscillator signal that is connected to the TCLK pin (pin number 152) is routed to an internal clock buffer. This is illustrated in Figure 7.



**Figure 7. Using an External Single-ended Clock Oscillator**

Frequency	14 to 24 MHz
Jitter Tolerance	250 ps
Rise Time (10% to 90%)	5 ns
Maximum Duty Cycle	40-60

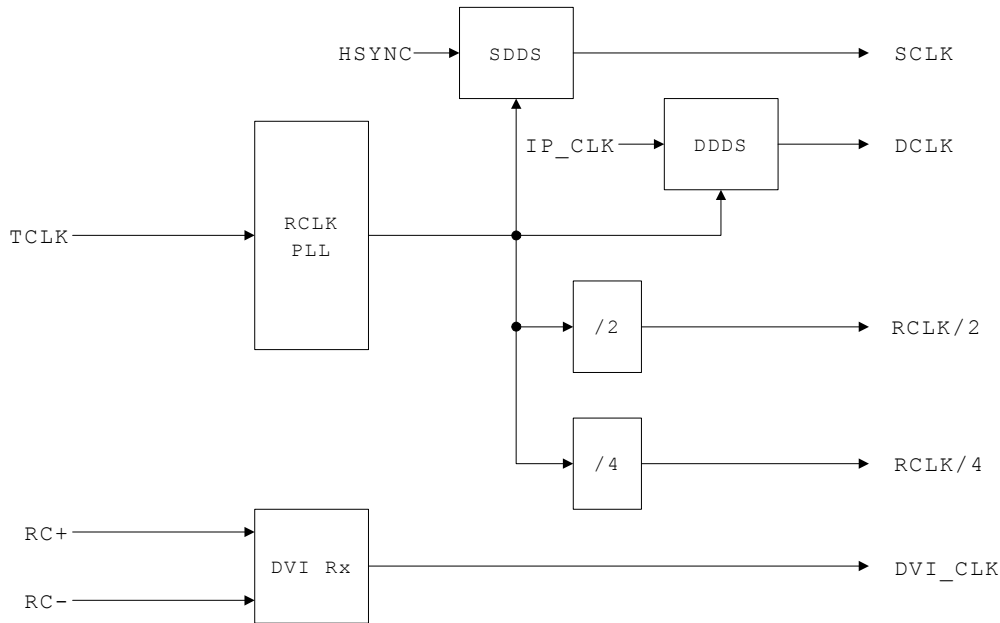
**Table 13. TCLK Specification**

### 4.1.3 Clock Synthesis

The gm5110/20 synthesizes all additional clocks internally as illustrated in Figure 8 below. The synthesized clocks are as follows:

1. Main Timing Clock (TCLK) is the output of the chip internal crystal oscillator. TCLK is derived from the TCLK/XTAL pad input.
2. Reference Clock (RCLK) synthesized by RCLK PLL (RPLL) using TCLK as the reference.
3. DVI Input Clock (DVI\_CLK) synthesized by DVI receiver PLL using RC+/RC- pair as the reference.
4. Input Source Clock (SCLK) synthesized by Source DDS (SDDS) PLL using input HSYNC as the reference. The SDDS internal digital logic is driven by RCLK.

5. Display Clock (DCLK) synthesized by Destination DDS (DDDS) PLL using IP\_CLK as the reference. The DDDS internal digital logic is driven by RCLK.
6. Half Reference Clock (RCLK/2) is the RCLK (see 2, above) divided by 2. Used as OCM\_CLK domain driver.
7. Quarter Reference Clock (RCLK/4) is the RCLK (see 2, above) divided by 4. Used as alternative clock (faster than TCLK) to drive IFM.
8. ADC Output Clock (SENSE\_ACLK) is a delay-adjusted ADC sampling clock, ACLK. ACLK is derived from SCLK.

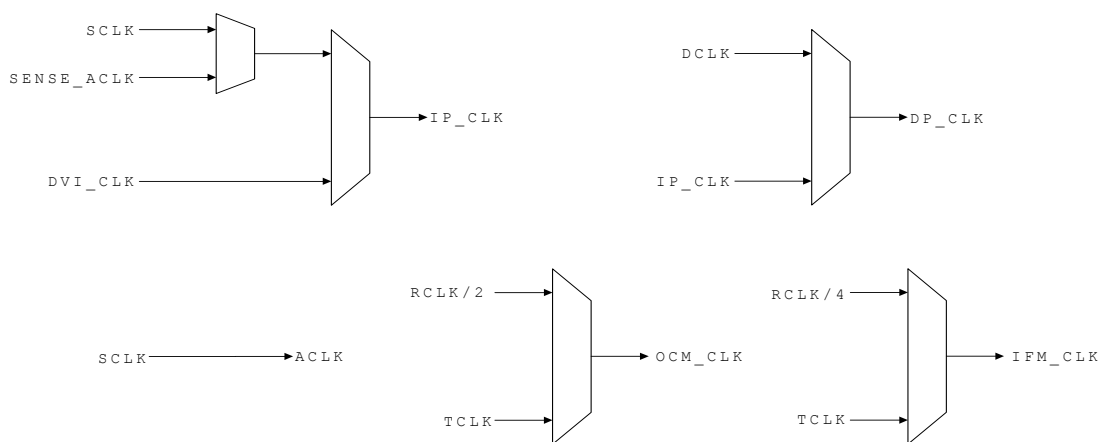


**Figure 8. Internally Synthesized Clocks**

The on-chip clock domains are selected from the synthesized clocks as shown in Figure 9 below. These include:

1. Input Domain Clock (IP\_CLK). Max = 165MHz
2. Host Interface and On-Chip Microcontroller Clock (OCM\_CLK). Max = 100MHz
3. Filter and Display Pixel Clock (DP\_CLK). Max = 135MHz
4. Source Timing Measurement Domain Clock (IFM\_CLK). Max = 50MHz
5. ADC Domain Clock (ACLK). Max = 165MHz.

The clock selection for each domain as shown in the figure below is controlled using the CLOCK\_CONFIG registers (index 0x03 and 0x04).



**Figure 9. On-chip Clock Domains**

## 4.2 Hardware Reset

Hardware Reset is performed by holding the RESETn pin low for a minimum of 1 $\mu$ s. A TCLK input (see Clock Options above) must be applied during and after the reset. When the reset period is complete and RESETn is de-asserted, the power-up sequence is as follows:

1. Reset all registers of all types to their default state (this is 00h unless otherwise specified in the gm5110/20 Register Listing).
2. Force each clock domain into reset. Reset will remain asserted for 64 local clock domain cycles following the de-assertion of RESETn.
3. Operate the OCM\_CLK domain at the TCLK frequency.
4. Preset the RCLK PLL to output ~200MHz clock (assumes 14.3MHz TCLK crystal frequency).
5. Wait for RCLK PLL to Lock. Then, switch the OCM\_CLK domain to operate from the bootstrap selected clock.
6. If a pull-up resistor is installed on ROM\_ADDR9 pin (see Table 18), then the OCM becomes active as soon as OCM\_CLK is stable. Otherwise, the OCM remains in reset until OCM\_CONTROL register (0x22) bit 1 is enabled.

## 4.3 Analog to Digital Converter

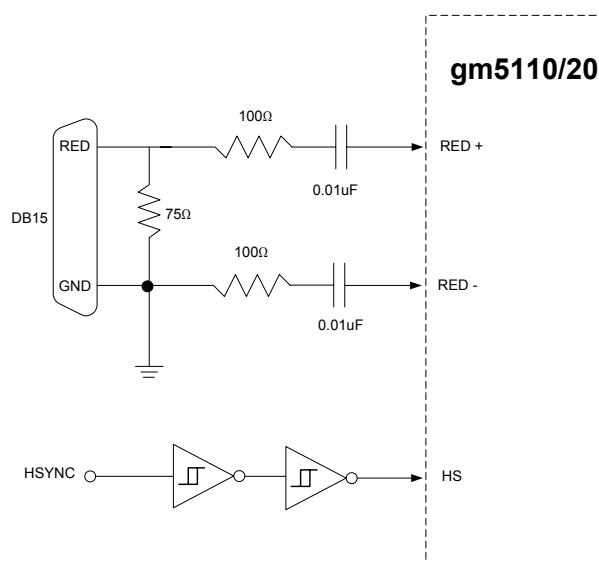
The gm5110/20 chip has three ADC's (analog-to-digital converters), one for each color (red, green, and blue).

### 4.3.1 ADC Pin Connection

The analog RGB signals are connected to the gm5110/20 as described below:

**Table 14. Pin Connection for RGB Input with HSYNC/VSYNC**

Pin Name	ADC Signal Name
Red+	Red
Red-	Terminate as illustrated in Figure 10
Green+	Green
Green-	Terminate as illustrated in Figure 10
Blue+	Blue
Blue-	Terminate as illustrated in Figure 10
HSYNC	Horizontal Sync (Terminate as illustrated in Figure 10)
VSYNC	Vertical Sync (Terminate as with HSYNC illustrated in Figure 10)



**Figure 10. Example ADC Signal Terminations**

Please note that it is very important to follow the recommended layout guidelines for the circuit shown in Figure 10. These are described in "gm5115 Layout Guidelines" document number C5115-SLG-01A.

### 4.3.2 ADC Characteristics

The table below summarizes the characteristics of the ADC:

**Table 15. ADC Characteristics**

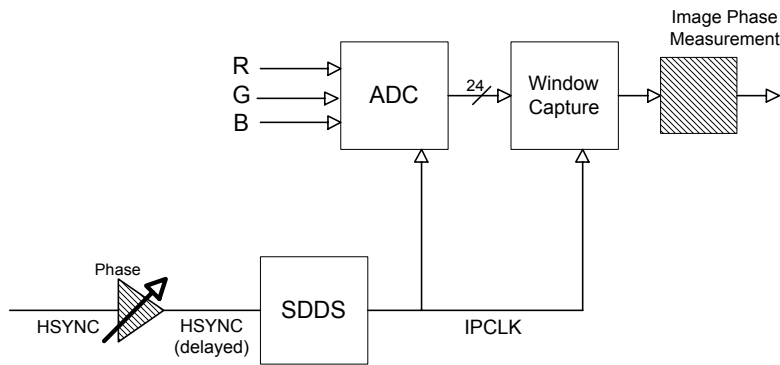
	MIN	TYP	MAX	NOTE
Track & Hold Amp Bandwidth		290 MHz		Guaranteed by design. Note that the Track & Hold Amp Bandwidth is programmable. 290 MHz is the maximum setting.
Full Scale Adjust Range at RGB Inputs	0.55 V		0.90 V	
Full Scale Adjust Sensitivity		+/- 1 LSB		Measured at ADC Output. Independent of full scale RGB input.
Zero Scale Adjust Sensitivity		+/- 1 LSB		Measured at ADC Output.
Sampling Frequency (Fs)	10 MHz		162.5 MHz	
Differential Non-Linearity (DNL)		+/-0.5 LSB	+/-0.9 LSB	Fs = 135 MHz
No Missing Codes				Guaranteed by test.
Integral Non-Linearity (INL)		+/- 1.5 LSB		Fs =135 MHz
Channel to Channel Matching		+/- 0.5 LSB		

The gm5110/20 ADC has a built in clamp circuit for AC-coupled inputs. By inserting series capacitors (about 10 nF), the DC offset of an external video source can be removed. The clamp pulse position and width are programmable.

### 4.3.3 Clock Recovery Circuit

The SDDS (Source Direct Digital Synthesis) clock recovery circuit generates the clock used to sample analog RGB data (IP\_CLK or source clock). This circuit is locked to HSYNC of the incoming video signal.

Patented digital clock synthesis technology makes the gm5110/20 clock circuits resistant to temperature/voltage drift. Using DDS (Direct Digital Synthesis) technology, the clock recovery circuit can generate any IP\_CLK clock frequency within the range of 10MHz to 165MHz.



**Figure 11. gm5110/20 Clock Recovery**

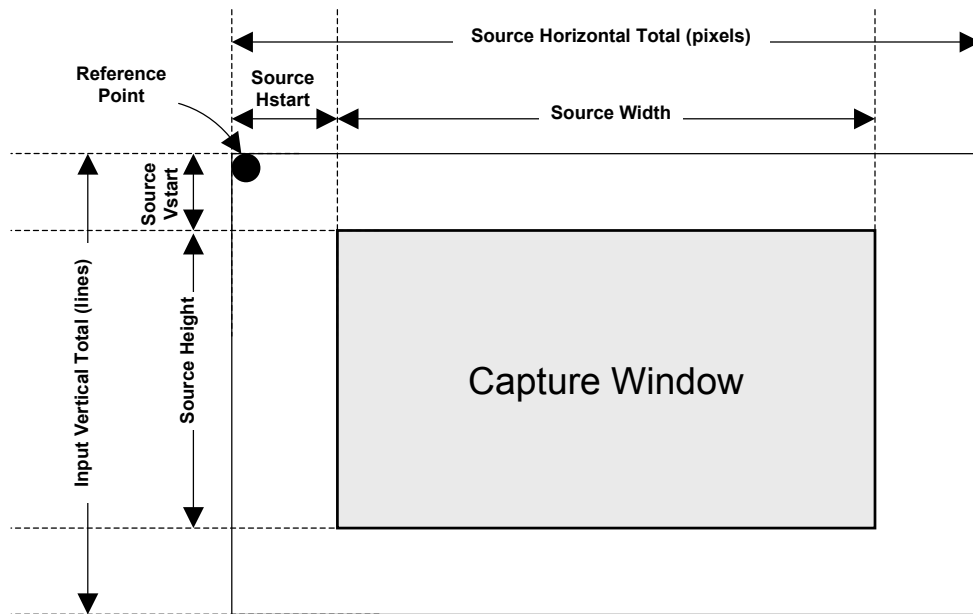
### 4.3.4 Sampling Phase Adjustment

The programmable ADC sampling phase is adjusted by delaying the HSYNC input to the SDDS. The accuracy of the sampling phase is checked and the result read from a register. This feature enables accurate auto-adjustment of the ADC sampling phase.

### 4.3.5 ADC Capture Window

Figure 12 below illustrates the capture window used for the ADC input. In the horizontal direction the capture window is defined in IP\_CLKs (equivalent to a pixel count). In the vertical direction it is defined in lines.

All the parameters beginning with “Source” are programmed gm5110/20 registers values. Note that the input vertical total is solely determined by the input and is not a programmable parameter.



**Figure 12. ADC Capture Window**

The Reference Point marks the leading edge of the first internal HSYNC following the leading edge of an internal VSYNC. Both the internal HSYNC and the internal VSYNC are derived from external HSYNC and VSYNC inputs.

Horizontal parameters are defined in terms of single pixel increments relative to the internal horizontal sync. Vertical parameters are defined in terms of single line increments relative to the internal vertical sync.

For ADC interlaced inputs, the gm5110/20 may be programmed to automatically determine the field type (even or odd) from the VSYNC/HSYNC relative timing. See Input Format Measurement, Section 4.5.

## 4.4 DVI Receiver Block

The Ultra-Reliable DVI™ receiver block of the gm5110/20 is compliant with DVI1.0 single link specifications. Digital Visual Interface (DVI) is a standard that uses Transition Minimized Differential Signaling protocol (TMDS). This block supports an input clock frequency ranging from 20 MHz to 165 MHz.

### 4.4.1 DVI Receiver Characteristics

Table 16 summarizes the characteristics of the four Receiver Pair inputs. Please note that it is very important to follow the recommended layout guidelines for these signals. These are described in "gm5115 Layout Guidelines" document number C5115-SLG-01A.

**Table 16. DVI Receiver Characteristics**

	MIN	TYP	MAX	NOTE
<b>DC Characteristics</b>				
Differential Input Voltage	150mV		1200mV	
Input Common Mode Voltage	AVDD -300m V		AVDD -37mV	
Behavior when Transmitter Disable	AVDD -10mV		AVDD +10mV	
<b>AC Characteristics</b>				
Input clock frequency	20 MHz		165 MHz	
Input differential sensitivity (Peak-to-peak)	150mV			
Max differential input (peak-to-peak)			1560 mV	
Allowable Intra-Pair skew at Receiver			250 ps	Input clock = 160 MHz
Allowable Inter-Pair skew at Receiver			4.0 ns	
Worst case differential input clock jitter tolerance			188 ps	

Through register programming, the receiver unit may be placed in one of three states:

- **Active:** The receiver block is fully on and running.
- **Standby:** Only the RC (clock) channel remains active. Data and other control signals are not decoded.
- **Off:** The receiver block is powered down.

#### 4.4.2 DVI Capture Window

DE (Display Enable), HSYNC and VSYNC are synthesized internally by examining the active regions of each line and compensating for possible source timing errors and/or embedded HSYNC / VSYNC jitter.

There are two ways to define the DVI capture region:

**CREF Capture** - In this mode the usual active window parameters must be programmed as with ADC inputs (see Section 4.3.5.).

**DE Capture** - In this mode the active window code embedded in the DVI signal defines the active window automatically. Only the active width and active length parameters obtained by performing Input Format Measurement (IFM) need be programmed.

#### 4.4.3 HDCP (High-Bandwidth Digital Content Protection)

The HDCP system allows authentication of a video receiver by a video transmitter, decryption of transmitter-encoded video data by the receiver, and periodic renew-ability of authentication during transmission. The gm5110/20 implements circuitry to allow full support of the HDCP 1.0 protocol for DVI inputs.

For enhanced security, Genesis provides a means of storing and accessing the secret key given to individual monitor units in an encrypted format. To use HDCP it is necessary to obtain the HDCP key encryption tool, called Gencrypt, from Genesis. Gencrypt will only be made available to HDCP licensed customers.

Further details of the protocol and theory of the system can be found in the *High-bandwidth Digital Content Protection System* specification (see [www.digital-cp.com](http://www.digital-cp.com)).

Note that this section applies to the HDCP enabled chip versions gm5110-H and gm5120-H but not the standard versions gm5110 and gm5120.

#### 4.5 Test Pattern Generator (TPG)

The gm5110/20 contains hundreds of test patterns, some of which are shown in Figure 13. Once programmed, the gm5110/20 test pattern generator can replace a video source (e.g. a PC) during factory calibration and test. This simplifies the test procedure and eliminates the possibility of image noise being injected into the system from the source. The foreground and background colors are programmable. In addition, the gm5110/20 OSD controller can be used to produce other patterns.

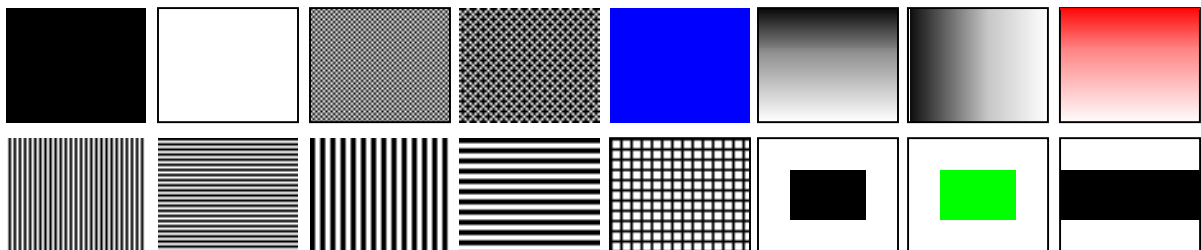


Figure 13. Some of gm5110/20 built-in test patterns

## 4.6 Input Format Measurement

The gm5110/20 has an Input Format Measurement block (the IFM) providing the capability of measuring the horizontal and vertical timing parameters of the input video source. This information may be used to determine the video format and to detect a change in the input format. It is also capable of detecting the field type of interlaced formats.

The IFM features a programmable reset, separate from the regular gm5110/20 soft reset. This reset disables the IFM, reducing power consumption. The IFM is capable of operating while gm5110/20 is running in power down mode.

Horizontal measurements are measured in terms of the selected IFM\_CLK (either TCLK or RCLK/4), while vertical measurements are measured in terms of HSYNC pulses.

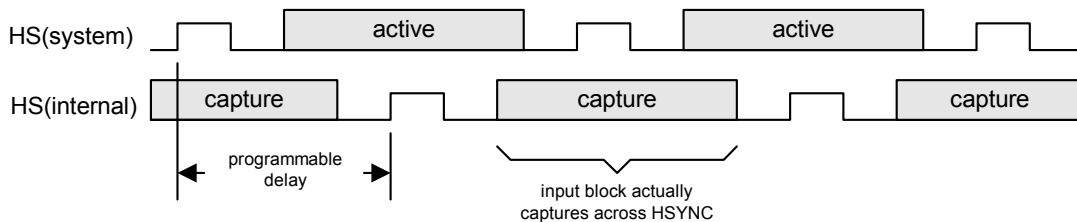
For an overview of the internally synthesized clocks, see section 4.1.

### 4.6.1 HSYNC / VSYNC Delay

The active input region captured by the gm5110/20 is specified with respect to internal HSYNC and VSYNC. By default, internal syncs are equivalent to the HSYNC and VSYNC at the input pins and thus force the captured region to be bounded by external HSYNC and VSYNC timing. However, the gm5110/20 provides an internal HSYNC and VSYNC delay feature that removes this limitation. This feature is available for use with both the ADC input and the DVI Rx (DE-regeneration mode). By delaying the sync internally, the gm5110/20 can capture data that spans across the sync pulse.

It is possible to use HSYNC and VSYNC delay for image positioning. (Alternatively, Source\_HSTART and Source\_VSTART in Figure 12 are used for image positioning of analog input.) Taken to an extreme, the intentional movement of images across apparent HSYNC and VSYNC boundaries creates a horizontal and/or vertical wrap effect.

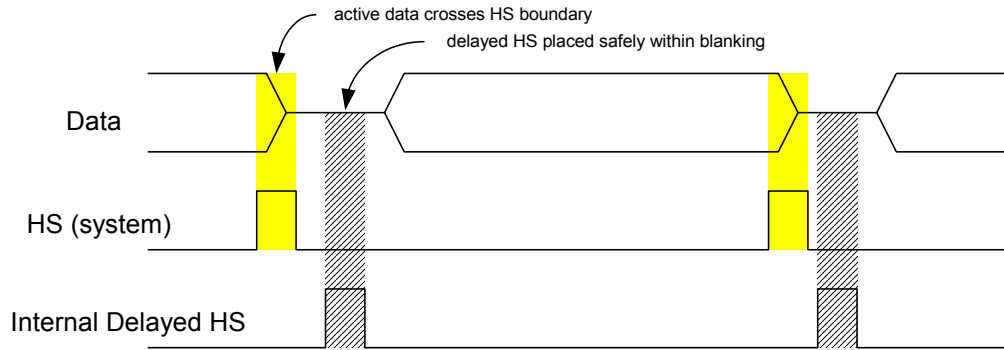
HSYNC is delayed by a programmed number of selected input clocks.



**Figure 14. HSYNC Delay**

Delayed horizontal sync may be used to solve a potential problem with VSYNC jitter with respect to HSYNC. VSYNC and HSYNC are generally driven active coincidentally, but with different paths to the gm5110/20 (HSYNC is often regenerated from a PLL). As a result, VSYNC may be seen earlier or later. Because VSYNC is used to reset the line

counter and HSYNC is used to increment it, any difference in the relative position of HSYNC and VSYNC is seen on-screen as vertical jitter. By delaying the HSYNC a small amount, it can be ensured that VSYNC always resets the line counter prior to it being incremented by the “first” HSYNC.



**Figure 15. Active Data Crosses HSYNC Boundary**

#### 4.6.2 Horizontal and Vertical Measurement

The IFM is able to measure the horizontal period and active high pulse width of the HSYNC signal, in terms of the selected clock period (either TCLK or RCLK/4.). Horizontal measurements are performed on only a single line per frame (or field). The line used is programmable. It is able to measure the vertical period and VSYNC pulse width in terms of rising edges of HSYNC.

Once enabled, measurement begins on the rising VSYNC and is completed on the following rising VSYNC. Measurements are made on every field / frame until disabled.

#### 4.6.3 Format Change Detection

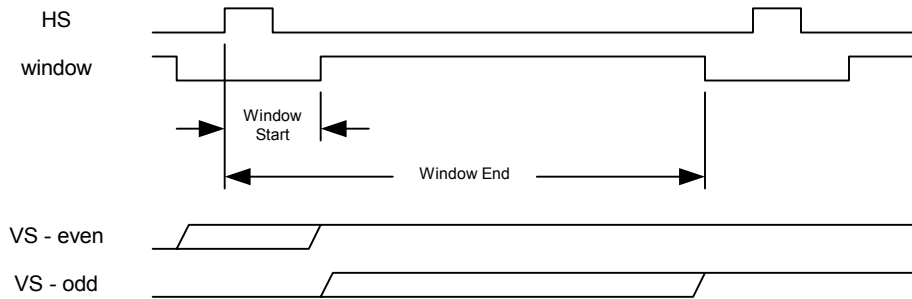
The IFM is able to detect changes in the input format relative to the last measurement and then alert both the system and the on-chip microcontroller. The microcontroller sets a measurement difference threshold separately for horizontal and vertical timing. If the current field / frame timing is different from the previously captured measurement by an amount exceeding this threshold, a status bit is set. An interrupt can also be programmed to occur.

#### 4.6.4 Watchdog

The watchdog monitors input VSYNC / HSYNC. When any HSYNC period exceeds the programmed timing threshold (in terms of the selected IFM\_CLK), a register bit is set. When any VSYNC period exceeds the programmed timing threshold (in terms of HSYNC pulses), a second register bit is set. An interrupt can also be programmed to occur.

#### 4.6.5 Internal Odd/Even Field Detection (For Interlaced Inputs to ADC Only)

The IFM has the ability to perform field decoding of interlaced inputs to the ADC. The user specifies start and end values to outline a “window” relative to HSYNC. If the VSYNC leading edge occurs within this window, the IFM signals the start of an ODD field. If the VSYNC leading edge occurs outside this window, an EVEN field is indicated (the interpretation of odd and even can be reversed). The window start and end points are selected from a predefined set of values.



**Figure 16. ODD/EVEN Field Detection**

#### 4.6.6 Input Pixel Measurement

The gm5110/20 provides a number of pixel measurement functions intended to assist in configuring system parameters such as pixel clock, SDDS sample clocks per line and phase setting, centering the image, or adjusting the contrast and brightness.

#### 4.6.7 Image Phase Measurement

This function measures the sampling phase quality over a selected active window region. This feature may be used when programming the source DDS to select the proper phase setting. Please refer to the gm5110/20 Programming Guide for the optimized algorithm.

### 4.6.8 Image Boundary Detection

The gm5110/20 performs measurements to determine the image boundary. This information is used when programming the Active Window and centering the image.

### 4.6.9 Image Auto Balance

The gm5110/20 performs measurements on the input data that is used to adjust brightness and contrast.

## 4.7 RealColor™ Digital Color Controls

The gm5110/20 provides high-quality digital color controls. These consist of a subtractive "black level" stage, followed by a full 3x3 RGB matrix multiplication stage, followed by a signed offset stage as shown in Figure 17.

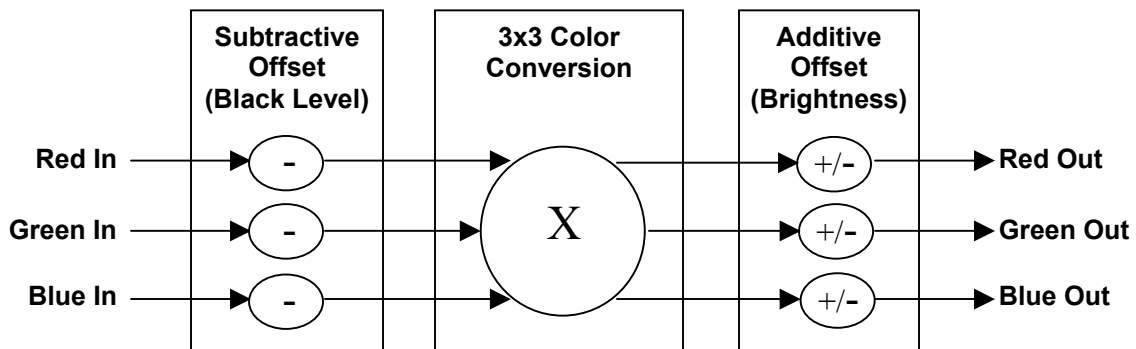


Figure 17. RealColor™ Digital Color Controls

This structure can accommodate all RGB color controls such as black-level (subtractive stage), contrast (multiplicative stage), and brightness (signed additive offset). In addition, it supports all YUV color controls including brightness (additive factor applied to Y), contrast (multiplicative factor applied to Y), hue (rotation of U and V through an angle) and saturation (multiplicative factor applied to both Y and V).

To provide the highest color purity all mathematical functions use 10 bits of accuracy. The final result is then dithered to eight or six bits (as required by the LCD panel).

### 4.7.1 RealColor™ Flesh tone Adjustment

The human eye is more sensitive to variations of flesh tones than other colors; for example, the user may not care if the color of grass is modified slightly during image capture and/or display. However, if skin tones are modified by even a small amount, it is unacceptable. The gm5110/20 features flesh tone adjustment capabilities. This feature is not based on lookup

tables, but rather a manipulation of YUV-channel parameters. Flesh tone adjustment is available for all inputs.

#### 4.7.2 Color Standardization and sRGB Support

Internet shoppers may be very picky about what color they experience on the display. gm5110/20 RealColor™ digital color controls can be used to make the color response of an LCD monitor compliant with standard color definitions, such as sRGB. sRGB is a standard for color exchange proposed by Microsoft and HP (see [www.srgb.com](http://www.srgb.com)). gm5110/20 RealColor controls can be used to make LCD monitors sRGB compliant, even if the native response of the LCD panel itself is not. For more information on sRGB compliance using gm5110/20 family devices please refer to the sRGB application brief C5115-APB-02A.

### 4.8 High-Quality Scaling

The gm5110/20 zoom scaler uses an adaptive scaling technique proprietary to Genesis Microchip Inc., and provides high quality scaling of real time video and graphics images. An input field/frame is scalable in both the vertical and horizontal dimensions.

Interlaced fields may be spatially de-interlaced by vertically scaling and repositioning the input fields to align with the output display's pixel map.

#### 4.8.1 Variable Zoom Scaling

The gm5110/20 scaling filter can combine its advanced scaling with a pixel-replication type scaling function. This is useful for improving the sharpness and definition of graphics when scaling at high zoom factors (such as VGA to XGA).

#### 4.8.2 Horizontal and Vertical Shrink

A shrink function may be performed on the input data. This is an arbitrary horizontal active resolution reduction to between (50% + 1 pixel) to 100% of the input. For example, this allows SXGA 1280 pixels to be displayed as 1024 (XGA).

The gm5110/20 provides an arbitrary vertical shrink down to (50% + 1 line) of the original image size. Together with the arbitrary horizontal shrink, this allows the gm5110/20 to capture and display images one VESA standard format larger than the native display resolution. For example, SXGA may be captured and displayed on an XGA panel.

### 4.8.3 Moiré Cancellation

The gamma curve and other non-linearities can affect the energy distribution of pixels when scaled to different areas of the screen. This is an example of the Moiré effect. The gm5110/20 has hardware features to negate the Moiré effect, improving the scaling quality.

### 4.9 Bypass Options

The gm5110/20 has the capability to completely bypass internal processing. In this case, captured input signals and data are passed, with a small register latency, straight through to the display output.

The gm5110/20 is also able to bypass the zoom filter.

### 4.10 Gamma LUT

The gm5110/20 provides an 8 to 10-bit look-up table (LUT) for each input color channel intended for Gamma correction and to compensate for a non-linear response of the LCD panel. A 10-bit output results in an improved color depth control. The 10-bit output is then dithered down to 8 bits (or 6 bits) per channel at the display (see section 4.11.3 below). The LUT is user programmable to provide an arbitrary transfer function. Gamma correction occurs after the zoom / shrink scaling block.

The LUT has bypass enable. If bypassed, the LUT does not require programming.

### 4.11 Display Output Interface

The Display Output Port provides data and control signals that permit the gm5110/20 to connect to a variety of flat panel or CRT devices. The output interface is configurable for 18 or 24-bit RGB pixels, either single or double pixel wide. All display data and timing signals are synchronous with the DCLK output clock.

#### 4.11.1 Display Synchronization

Refer to section 4.1 for information regarding internal clock synthesis.

The gm5110/20 supports the following display synchronization modes:

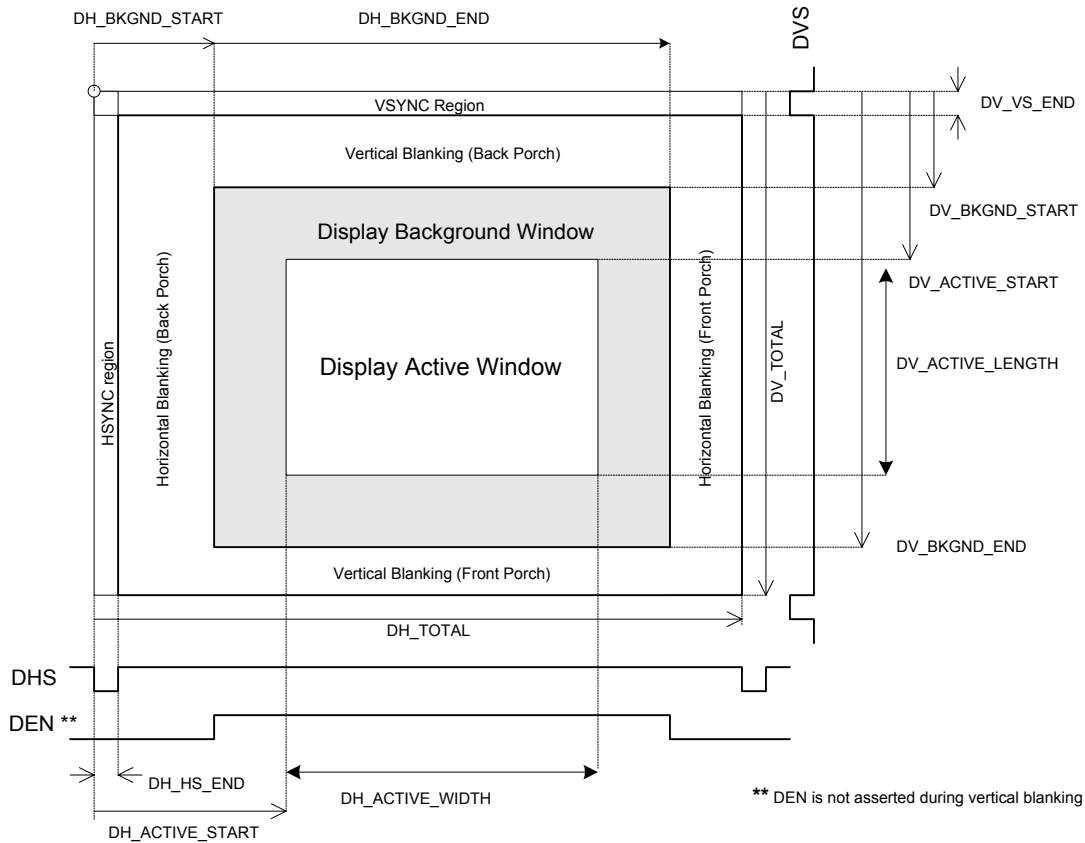
- **Frame Sync Mode:** The display frame rate is synchronized to the input frame or field rate. This mode is used for standard operation.
- **Free Run Mode:** No synchronization. This mode is used when there is no valid input timing (i.e. to display OSD messages or a splash screen) or for testing purposes. In

free-run mode, the display timing is determined only by the values programmed into the display window and timing registers.

### 4.11.2 Programming the Display Timing

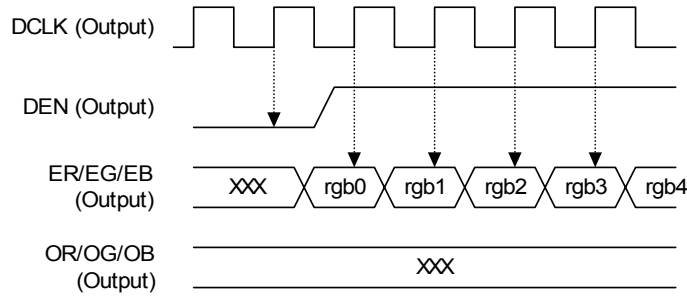
Display timing signals provide timing information so the Display Port can be connected to an external display device. Based on values programmed in registers, the Display Output Port produces the horizontal sync (DHS), vertical sync (DVS), and data enable (DEN) control signals. The figure below provides the registers that define the output display timing.

Horizontal values are programmed in single pixel increments relative to the leading edge of the horizontal sync signal. Vertical values are programmed in line increments relative to the leading edge of the vertical sync signal.

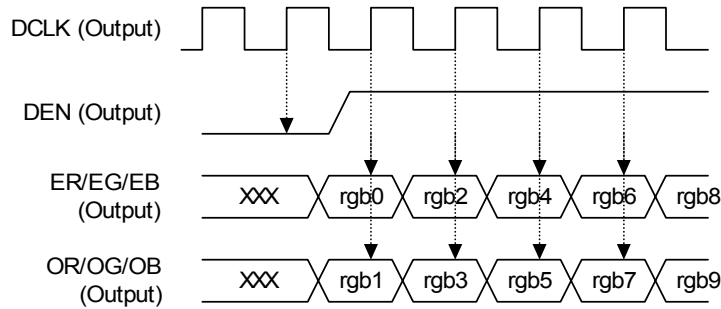


**Figure 18. Display Windows and Timing**

The double-wide output only supports an even number of horizontal pixels.



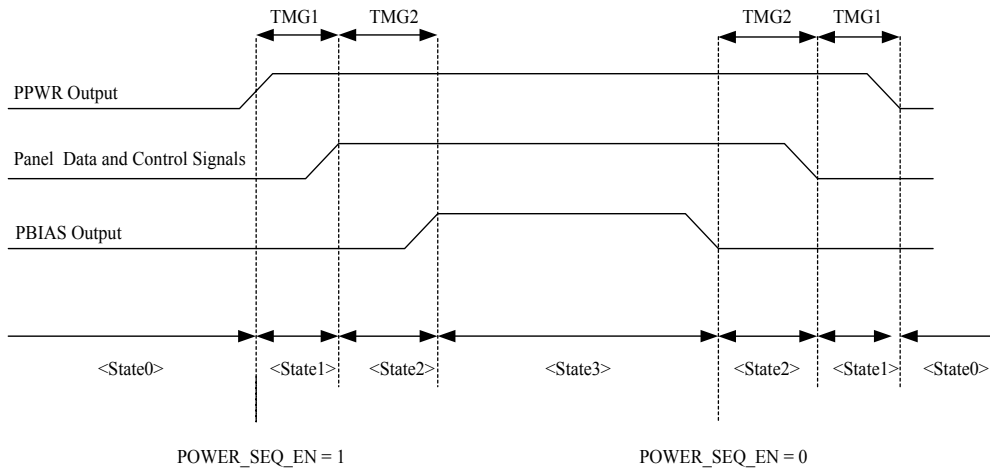
**Figure 19. Single Pixel Width Display Data**



**Figure 20. Double Pixel Wide Display Data**

**4.11.3 Panel Power Sequencing (PPWR, PBIAS)**

gm5110/20 has two dedicated outputs PPWR and PBIAS (pins 113 and 114) to control LCD power sequencing once data and control signals are stable. The timing of these signals is fully programmable.



**Figure 21. Panel Power Sequencing**

#### 4.11.4 Output Dithering

The Gamma LUT outputs a 10-bit value for each color channel. This value is dithered down to either 8-bits for 24-bit per pixel panels, or 6-bits for 18-bit per pixel panels.

The benefit of dithering is that the eye tends to average neighboring pixels and a smooth image free of contours is perceived. Dithering works by spreading the quantization error over neighboring pixels both spatially and temporally. Two dithering algorithms are available: random or ordered dithering. Ordered dithering is recommended when driving a 6-bit panel.

All gray scales are available on the panel output whether using 8-bit panel (dithering from 10 to 8 bits per pixel) or using 6-bit panel (dithering from 10 down to 6 bits per pixel).

#### 4.12 Energy Spectrum Management (ESM)

High spikes in the EMI power spectrum may cause LCD monitor products to violate emissions standards. The gm5110/20 has many features that can be used to reduce electromagnetic interference (EMI). These include drive strength control and clock spectrum modulation. These features help to eliminate the costs associated with EMI reducing components and shielding.

#### 4.13 OSD

The gm5110/20 has a fully programmable, high-quality OSD controller. The graphics are divided into “cells” 12 by 18 pixels in size. The cells are stored in an on-chip static RAM (4096 words by 24 bits) and can be stored as 1-bit per pixel data, 2-bit per pixel data or 4-bit per pixel data. This permits a good compression ratio while allowing more than 16 colors in the image.

Some general features of the gm5110/20 OSD controller include:

**OSD Position** – The OSD menu can be positioned anywhere on the display region. The reference point is Horizontal and Vertical Display Background Start (DH\_BKGND\_START and DV\_BKGND\_START in Figure 18).

**OSD Stretch** – The OSD image can be stretched horizontally and/or vertically by a factor of two, three, or four. Pixel and line replication is used to stretch the image.

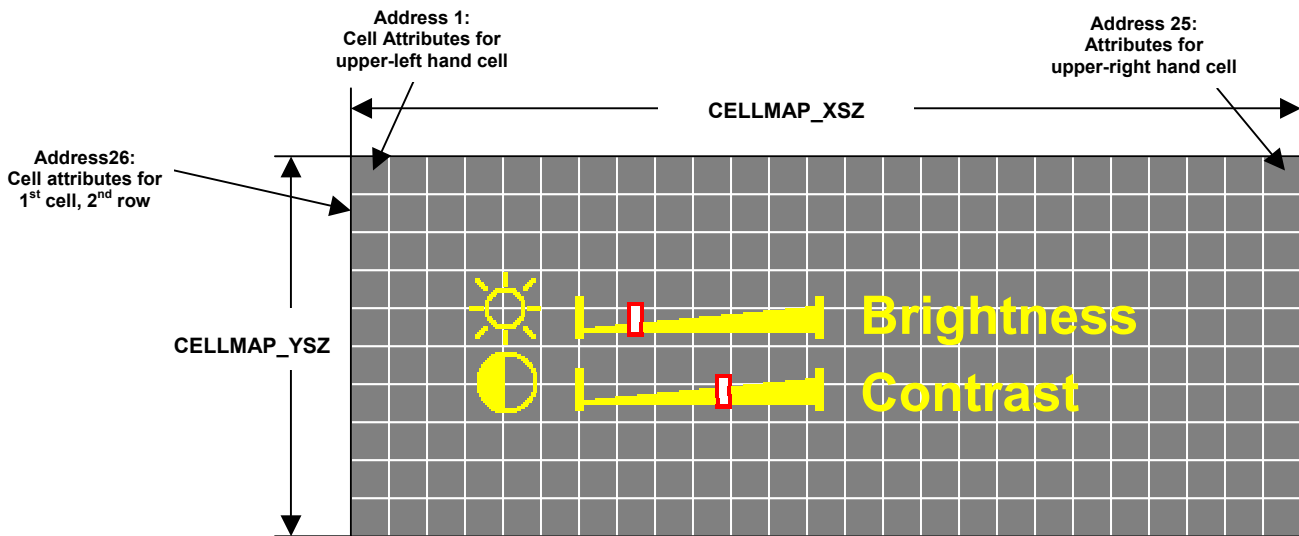
**OSD Blending** – Sixteen levels of blending are supported for the character-mapped and bitmapped images. One host register controls the blend levels for pixels with LUT values of 128 and greater, while another host register controls the blend levels for pixels with LUT values of 127 and lower. OSD color LUT value 0 is reserved for transparency and is unaffected by the blend attribute.

### 4.13.1 On-Chip OSD SRAM

The on-chip static RAM (4096 words by 24 bits) stores the cell map and the cell definitions.

In memory, the cell map is organized as an array of words, each defining the attributes of one visible character on the screen starting from upper left of the visible character array. These attributes specify which character to display, whether it is stored as 1, 2 or 4 bits per pixel, the foreground and background colors, blinking, etc.

Registers CELLMAP\_XSZ and CELLMAP\_YSZ are used to define the visible area of the OSD image. For example, Figure 22 shows a cell map for which CELLMAP\_XSZ =25 and CELLMAP\_YSZ =10.



**Figure 22. OSD Cell Map**

Cell definitions are stored as bit map data. On-chip registers point to the start of 1-bit per pixel definitions, 2-bit per pixel definitions and 4-bit per pixel definitions respectively. 1, 2 and 4-bit per pixel cell definitions require 9, 18 and 36 words of the OSD RAM respectively.

Note that the cell map and the cell definitions share the same on-chip RAM. Thus, the size of the cell map can be traded off against the number of different cell definitions. In particular, the size of the OSD image and the number of cell definitions must fit in OSD SRAM. That is, the following inequality must be satisfied. (Note, the ROUND operation rounds 3.5 to 4).

$$\begin{aligned}
 &(\text{CELLMAP\_XSZ}+1) * \text{CELLMAP\_YSZ} + \\
 &18 * \text{ROUND}(\text{Number of 1-bit per pixel fonts} / 2) + \\
 &18 * (\text{Number of 2-bit per pixel fonts}) + \\
 &36 * (\text{Number of 4-bit per pixel fonts}) \leq 4096
 \end{aligned}$$

For example, an OSD menu 360 pixels wide by 360 pixels high is 30 cells in width and 20 cells in height. Many of these cells would be the same (e.g. empty). In this case, the menu

could contain more than 32 1-bit per pixel cells, 100 2-bit per pixel cells, and 16 4-bit per pixel cells. Of course, different numbers of each type can also be used.

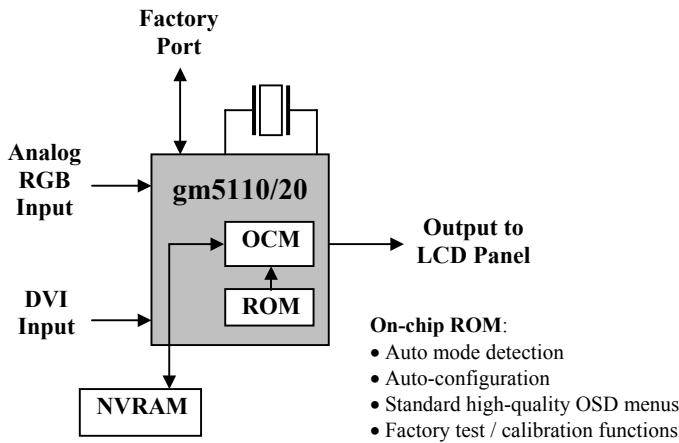
**4.13.2 Color Look-up Table (LUT)**

Each pixel of a displayed cell is resolved to an 8-bit color code. This selected color code is then transformed to a 24-bit value using a 256 x 24-bit look up table. This LUT is stored in an on-chip RAM that is separate from the OSD RAM. Color index value 0x00 is reserved for transparent OSD pixels.

**4.14 On-Chip Microcontroller (OCM)**

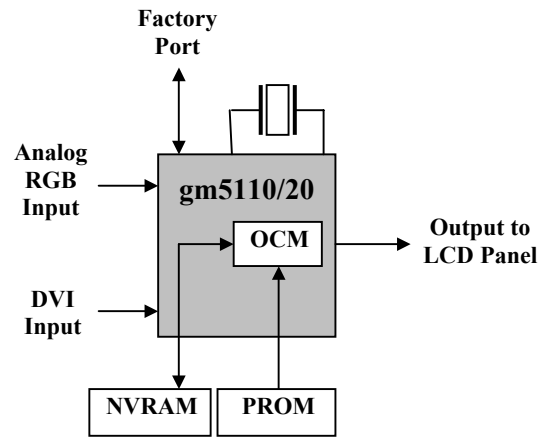
The gm5110/20 on-chip microcontroller (OCM) serves as the system microcontroller. It programs the gm5110/20 and manages other devices in the system such as the keypad, the back light and non-volatile RAM (NVRAM) using general-purpose input/output (GPIO) pins.

The OCM can operate in two configurations, Standalone configuration and Full-Custom configuration, as illustrated in Figure 23.



- Configuration settings in NVRAM:**
- OSD Colors, Logo and other configuration
  - Panel Parameters
  - Additional input modes
  - Code patches

**Figure 23A - Standalone Configuration**  
(No external ROM)



- |  |  |
|--|--|
| <b>User settings in NVRAM:</b>   | <b>External ROM:</b>   |
| <ul style="list-style-type: none"> <li>• Brightness/contrast settings, etc</li> <li>• On mode-by-mode basis</li> </ul> | <ul style="list-style-type: none"> <li>• Contains firmware code and data for all firmware functions</li> </ul> |

**Figure 23B - Full-Custom Configuration**  
(Program and Data stored in external ROM)

### 4.14.1 Standalone Configuration

Standalone configuration offers the most simple and inexpensive system solution for generic LCD monitors. In this configuration the OCM executes firmware stored internally in gm5110/20. This is illustrated in Figure 23A. The on-chip firmware provides all the standard functions required in a high-quality generic LCD monitor. This includes mode-detection, auto-configuration and a high-quality standard OSD menu system. No external ROM is required (which reduces BOM cost) and no firmware development effort is required (which reduces time-to-market).

In Standalone configuration many customization parameters are stored in NVRAM. These include the LCD panel timing parameters (including TCON programming), the color scheme and logos used in the OSD menus, the functions provided by the OSD menus, and arbitrary firmware modifications. These customization parameters are described in the Standalone User’s Guide (B0108-SUG-01). Based on the customization parameters, G-Wizard (a GUI-based development tool used to program Genesis devices) produces the hex image file for NVRAM. G-Probe is then used to download the NVRAM image file into the NVRAM device. This is illustrated in Figure 24 below.

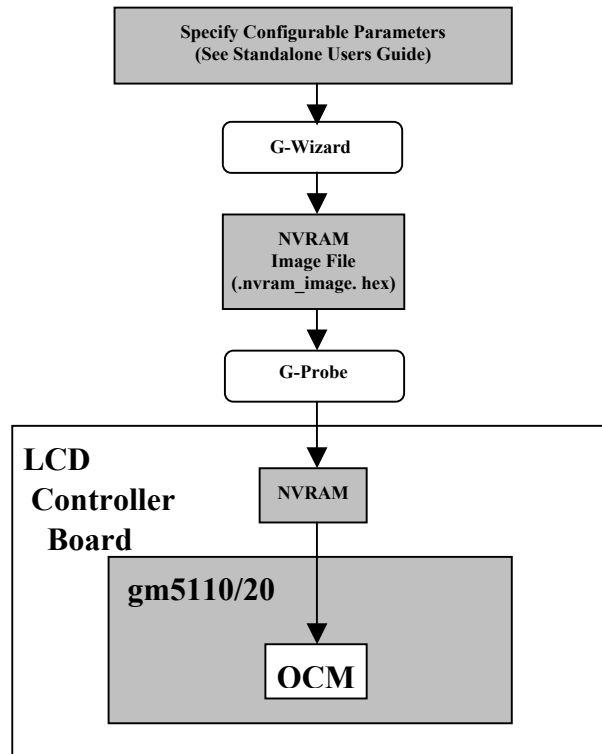


Figure 24. Programming OCM in Standalone Configuration

### 4.14.2 Full-Custom Configuration

In full-custom configuration the OCM executes a firmware program running from external ROM. This is illustrated in Figure 23B. A parallel port with separate address and data busses is available for this purpose. This port connects directly to standard, commercially available ROM or programmable Flash ROM devices. Normally 64KB or 128KB of ROM is required.

Both instructions and data are fetched from external ROM on a cycle-by-cycle basis. The speed of the accesses on the parallel port is determined by the gm5110/20 internal OCM\_CLK. This in turn determines the speed of the external ROM device. For example, if a 14.3 MHz crystal is being used to produce TCLK, and the OCM\_CLK is derived from TCLK, then a 45ns ROM can be used.

To program gm5110/20 in full-custom configuration the content of the external ROM is generated using Genesis software development tools G-Wizard and OSD-Workbench. This is illustrated in Figure 25. G-Wizard is a GUI-based tool for capturing system information such as panel timing, support modes, system configuration, etc. OSD-Workbench is a GUI based tool for defining OSD menus and functionality.

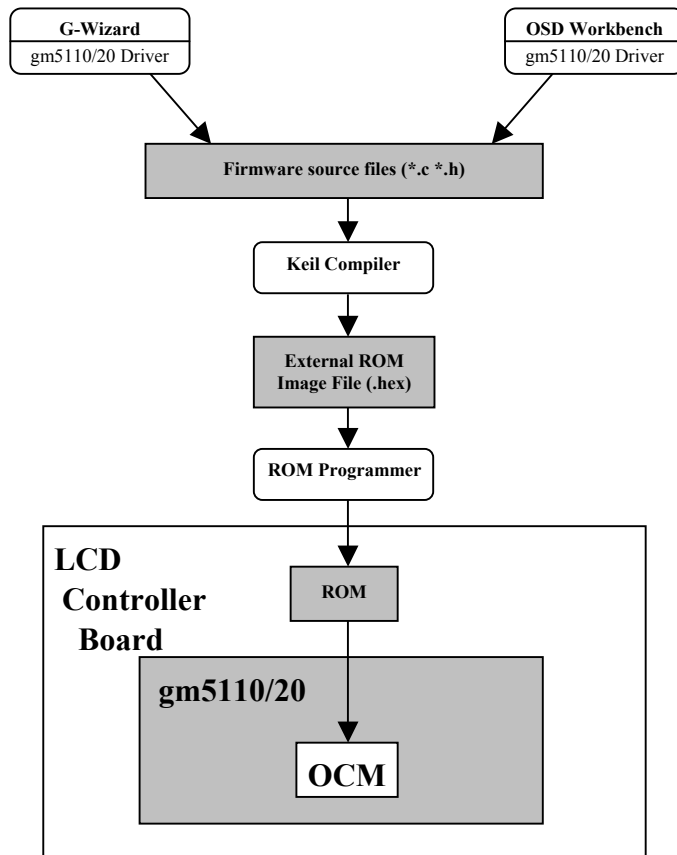


Figure 25. Programming the OCM in Full-Custom Configuration

Genesis recommends using Keil compiler (<http://www.keil.com/>) to compile the firmware source code into a hex file. This hex file is then downloaded into the external ROM using commercially available ROM programmers.

For development purposes it may be useful to use a ROM emulator. For example, a PROMJET ROM emulator can be used (<http://www.emutec.com/pjetmain.html>).

### 4.14.3 General Purpose Inputs and Outputs (GPIO's)

The gm5110/20 has 21 general-purpose input/output (GPIO) pins. These are used by the OCM to communicate with other devices in the system such as keypad buttons, NVRAM, LEDs, audio DAC, etc. Each GPIO has independent direction control, open drain enable, for reading and writing. Note that the GPIO pins have alternate functionality as described in Table 17 below.

Pin Name	Pin Number	Alternate function
GPIO0/PWM0	40	PWM0, PWM1 and PWM2 back light intensity controls, as described in section 4.17.2 below.
GPIO1/PWM1	41	
GPIO2/PWM2	42	
GPIO3/TIMER1	43	Timer1 input of the OCM.
GPIO4/UART_DI	44	OCM UART data in/out signals respectively.
GPIO5/UARD_D0	45	
GPIO6	46	
GPIO7	47	
GPIO8/IRQINn	39	OCM external interrupt source (IRQINn).
GPIO9	48	
GPIO10	49	
GPIO11/ROM_WEn	50	Write enable for external ROM if programmable FLASH device is used.
GPIO12/NVRAM_SDA	51	Data and clock lines for master 2-wire serial interface to NVRAM when gm5110/20 is used in standalone configuration (section Figure 23).
GPIO13/NVRAM_SCL	52	
GPIO14/DDC_SCL	6	Clock and data lines for 2-wire serial interface connected to the Direct Data Channel (DDC) of the DVI input, for passing HDCP keys.
GPIO15/DDC_SDA	7	
GPIO16/HFSn	205	Serial data line for 2-wire host interface.
GPIO17	1	
GPIO18	208	
GPIO19	207	
GPIO20	206	
GPIO21/IRQn	4	
GPIO22/HCLK	204	Serial input clock for 2-wire host interface.
GPO0	119	General-purpose outputs.
GPO1	120	
GPO2	121	
GPO3	122	
GPO4	123	
GPO5	124	
GPO6	125	
GPO7	126	

Table 17. gm5110/20 GPIOs and Alternate Functions

### 4.15 Bootstrap Configuration Pins

During hardware reset, the external ROM address pins ROM\_ADDR[15:0] are configured as inputs. On the negating edge of RESETn, the value on these pins is latched and stored. This value is readable by the on-chip microcontroller (or an external microcontroller via the host

interface). Install a 10K pull-up resistor to indicate a ‘1’, otherwise a ‘0’ is indicated because ROM\_ADDR[15:0] have a 60KΩ internal pull-down resistor.

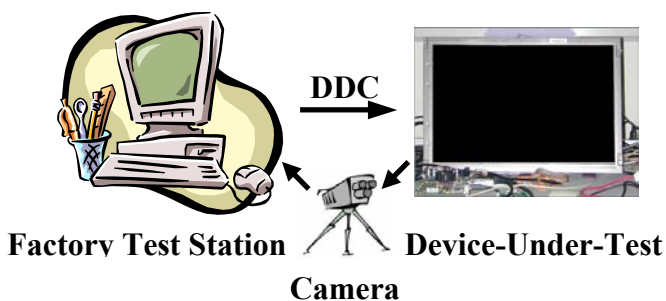
Signal Name	Pin Name	Description
HOST_ADDR(6:0)	ROM_ADDR(6:0)	If using 2-wire host protocol, these are the serial bus device address.
HOST_PROTOCOL	ROM_ADDR7	Program this bit to 0 for 2-wire host interface operation.
HOST_PORT_EN	ROM_ADDR8	Program this bit to 0 for 2-wire host interface operation.
OCM_START	ROM_ADDR9	Determines the operating condition of the OCM after HW reset: 0 = OCM remains in reset until enabled by register bit. 1 = OCM becomes active after OCM_CLK is stable.
USER_BITS(7:5)	ROM_ADDR(12:10)	These settings are available for reading from a status register but are otherwise unused by the gm5110/20. Used to allow the OCM or external MCU access configuration settings.
OSC_SEL	ROM_ADDR13	Selects reference clock source (refer to Figure 7): 0 = XTAL and TCLK pins are connected to a crystal oscillator. 1 = TCLK input is driven with a single-ended TTL/CMOS clock oscillator.
OCM_ROM_CNFG(1)	ROM_ADDR14	Together with OCM_CONTROL register (0x22) bit 4, this bit selects internal/external ROM configuration. 0 = All 48K of ROM is internal. 1 = All 48K of ROM is in external ROM using ROM_ADDR15:0 address outputs if register 0x22 bit 4 is 0. If register 0x22 bit 4 is 1, 0-32K ROM is internal, and 32K-48K ROM is external using ROM_ADDR13:0 address outputs.

**Table 18. Bootstrap Signals**

### 4.16 Host Interface

A serial host interface is provided to allow an external device to peek and poke registers in the gm5110/20. This is done using a 2-wire serial protocol. Note that 2-wire host interface requires bootstrap settings as described in Table 18.

The 2-wire host interface is suitable for connection to a factory interrogation port. This is illustrated in Figure 26. The factory test station connects to the gm5110/20 through the Direct Data Channel (DDC) of the DSUB15 or DVI connectors. For example, the PC can make gm5110/20 display test patterns (see section 4.5). A camera can be used to automate the calibration of the LCD panel.



**Figure 26. Factory Calibration and Test Environment**

An arbitration mechanism ensures that register accesses from the OCM and the 2-wire host interface port are always serviced (time division multiplexing).

### 4.16.1 Host Interface Command Format

Transactions on the 2-wire host protocol occurs in integer multiples of bytes (i.e. 8 bits or two nibbles respectively). These form an instruction byte, a device register address and/or one or more data bytes. This is described in Table 19.

The first byte of each transfer indicates the type of operation to be performed by the gm5110/20. The table below lists the instruction codes and the type of transfer operation. The content of bytes that follow the instruction byte will vary depending on the instruction chosen. By utilizing these modes effectively, registers can be quickly configured.

The two LSBs of the instruction code, denoted 'A9' and 'A8' in Table 19 below, are bits 9 and 8 of the internal register address respectively. Thus, they should be set to '00' to select a starting register address of less than 256, '01' to select an address in the range 256 to 511, and '10' to select an address in the range 512 to 767. These bits of the address increment in Address Increment transfers. The unused bits in the instruction byte, denoted by 'x', should be set to '1'.

**Table 19. Instruction Byte Map**

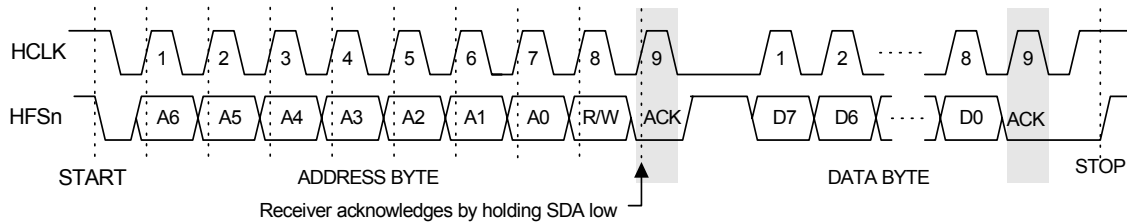
Bit 7 6 5 4 3 2 1 0	Operation Mode	Description
0 0 0 1 x x A9 A8	Write Address Increment	Allows the user to write a single or multiple bytes to a specified starting address location. A Macro operation will cause the internal address pointer to increment after each byte transmission. Termination of the transfer will cause the address pointer to increment to the next address location.
0 0 1 0 x x A9 A8	Write Address No Increment (for table loading)	
1 0 0 1 x x A9 A8	Read Address Increment	Allows the user to read multiple bytes from a specified starting address location. A Macro operation will cause the internal address pointer to increment after each read byte. Termination of the transfer will cause the address pointer to increment to the next address location.
1 0 1 0 x x A9 A8	Read Address No Increment (for table reading)	
0 0 1 1 x x A9 A8 0 1 0 0 x x A9 A8 1 0 0 0 x x A9 A8 1 0 1 1 x x A9 A8 1 1 0 0 x x A9 A8	Reserved	
0 0 0 0 x x A9 A8 0 1 0 1 x x A9 A8 0 1 1 0 x x A9 A8 0 1 1 1 x x A9 A8 1 1 0 1 x x A9 A8 1 1 1 0 x x A9 A8 1 1 1 1 x x A9 A8	Spare	No operation will be performed

### 4.16.2 2-wire Serial Protocol

The 2-wire protocol consists of a serial clock HCLK (pin number 204) and bi-directional serial data line HFSn (pin number 205). The bus master drives HCLK and either the master or slave can drive the HFSn line (open drain) depending on whether a read or write operation is being performed. The gm5110/20 operates as a slave on the interface.

The 2-wire protocol requires each device be addressable by a 7-bit identification number. The gm5110/20 is initialized on power-up to 2-wire mode by asserting bootstrap pins HOST\_PROTOCOL=0 and the device identification number on HOST\_ADDR(6:0) on the rising edge of RESETn (see Table 18). This provides flexibility in system configuration with multiple devices that can have the same address.

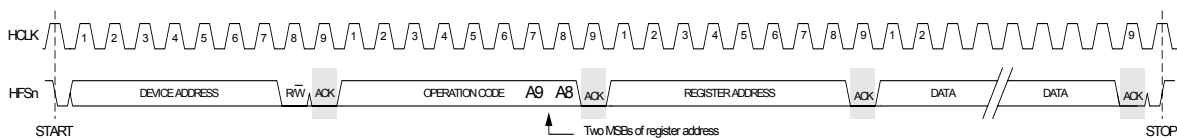
A 2-wire data transfer consists of a stream of serially transmitted bytes formatted as shown in the figure below. A transfer is initiated (START) by a high-to-low transition on HFSn while HCLK is held high. A transfer is terminated by a STOP (a low-to-high transition on HFSn while HCLK is held high) or by a START (to begin another transfer). The HFSn signal must be stable when HCLK is high, it may only change when HCLK is low (to avoid being misinterpreted as START or STOP).



**Figure 27. 2-Wire Protocol Data Transfer**

Each transaction on the HFSn is in integer multiples of 8 bits (i.e. bytes). The number of bytes that can be transmitted per transfer is unrestricted. Each byte is transmitted with the most significant bit (MSB) first. After the eight data bits, the master releases the HFSn line and the receiver asserts the HFSn line low to acknowledge receipt of the data. The master device generates the HCLK pulse during the acknowledge cycle. The addressed receiver is obliged to acknowledge each byte that has been received.

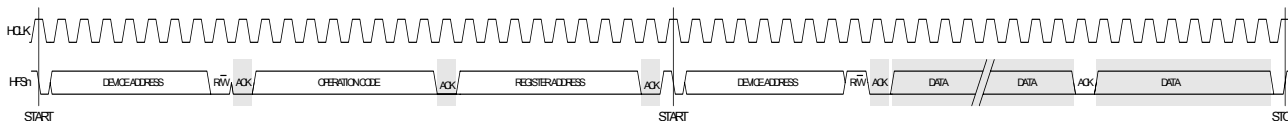
The Write Address Increment and the Write Address No Increment operations allow one or multiple registers to be programmed with only sending one start address. In Write Address Increment, the address pointer is automatically incremented after each byte has been sent and written. The transmission data stream for this mode is illustrated in Figure 28 below. The highlighted sections of the waveform represent moments when the transmitting device must release the HFSn line and wait for an acknowledgement from the gm5110/20 (the slave receiver).



**Figure 28. 2-Wire Write Operations (0x1x and 0x2x)**

The Read Address Increment (0x90) and Read Address No Increment (0xA0) operations are illustrated in Figure 29. The highlighted sections of the waveform represent moments when the transmitting device must release the HFSn line and waits for an acknowledgement from the master receiver.

Note that on the last byte read, no acknowledgement is issued to terminate the transfer.



**Figure 29. 2-Wire Read Operation (0x9x and 0xAx)**

Please note that in all the above operations the operation code includes two address bits, as described in Table 19.

## 4.17 Miscellaneous Functions

### 4.17.1 Low Power State

The gm5110/20 provides a low power state in which the clocks to selected parts of the chip may be disabled (see Table 21).

### 4.17.2 Pulse Width Modulation (PWM) Back Light Control

Many of today's LCD back light inverters require both a PWM input and variable DC voltage to minimize flickering (due to the interference between panel timing and inverter's AC timing), and adjust brightness. Most LCD monitor manufacturers currently use a microcontroller to provide these control signals. To minimize the burden on the external microcontroller, the gm5110/20 generates these signals directly.

There are three pins available for controlling the LCD back light, PWM0 (GPIO0), PWM1 (GPIO1) and PWM2 (GPIO2). The duty cycle of these signals is programmable. They may be connected to an external RC integrator to generate a variable DC voltage for a LCD back light inverter. Panel HSYNC is used as the clock for a counter generating this output signal.

## 5. ELECTRICAL SPECIFICATIONS

The following targeted specifications have been derived by simulation.

### 5.1 Preliminary DC Characteristics

**Table 20. Absolute Maximum Ratings**

PARAMETER	SYMBOL	MIN	TYP	MAX	UNITS
3.3V Supply Voltages <sup>(1,2)</sup>	V <sub>VDD_3.3</sub>	-0.3		3.6	V
2.5V Supply Voltages <sup>(1,2)</sup>	V <sub>VDD_2.5</sub>	-0.3		2.75	V
Input Voltage (5V tolerant inputs) <sup>(1,2)</sup>	V <sub>IN5Vtol</sub>	-0.3		5.5	V
Input Voltage (non 5V tolerant inputs) <sup>(1,2)</sup>	V <sub>IN</sub>	-0.3		3.6	V
Electrostatic Discharge	V <sub>ESD</sub>			±2.0	kV
Latch-up	I <sub>LA</sub>			±100	mA
Ambient Operating Temperature	T <sub>A</sub>	0		70	°C
Storage Temperature	T <sub>STG</sub>	-40		125	°C
Operating Junction Temp.	T <sub>J</sub>	0		125	°C
Thermal Resistance (Junction to Air) Natural Convection <sup>(3)</sup>					
gm5110	θ <sub>JA_5110</sub>			32.4	°C/W
gm5120	θ <sub>JA_5120</sub>			22.0	
Thermal Resistance (Junction to Case) Convection <sup>(4)</sup>					
gm5110	θ <sub>JC_5110</sub>			13.9	°C/W
gm5120	θ <sub>JC_5120</sub>			10.1	
Soldering Temperature (30 sec.)	T <sub>SOL</sub>			220	°C
Vapor Phase Soldering (30 sec.)	T <sub>VAP</sub>			220	°C

**NOTE (1):** All voltages are measured with respect to GND

**NOTE (2):** Absolute maximum voltage ranges are for transient voltage excursions.

**NOTE (3):** Package thermal resistance is based on a PCB with one signal plane and two power planes. Package θ<sub>JA</sub> is improved on a PCB with four or more layers

**NOTE (4):** Based on the figures for the Operating Junction Temperature, θ<sub>JC</sub> and Power Consumption in Table 21, the typical case temperature is calculated as T<sub>C</sub> = T<sub>J</sub> - P x θ<sub>JC</sub>. This equals 104 degrees Celsius for gm5110 and 106 degrees Celsius for gm5120.

**Table 21. DC Characteristics**

PARAMETER	SYMBOL	MIN	TYP	MAX	UNITS
<b>POWER</b>					
Power Consumption @ 96 MHz (gm5110)	P <sub>5110</sub>		1.5		W
Power Consumption @ 135 MHz (gm5120)	P <sub>5120</sub>		1.8		W
Power Consumption @ Low Power Mode <sup>(1)</sup>	P <sub>LP</sub>		0.15		W
3.3V Supply Voltages (AVDD and RVDD)	V <sub>VDD_3.3</sub>	3.15	3.3	3.45	V
2.5V Supply Voltages (VDD and CVDD)	V <sub>VDD_2.5</sub>	2.35	2.5	2.65	V
Supply Current @ CLK = 96 MHz (gm5110)	I <sub>5110</sub>		400		mA
• 2.5V digital supply <sup>(2)</sup>	I <sub>5110_2.5_VDD</sub>			360 <sup>(6)</sup>	
• 2.5V analog supply <sup>(3)</sup>	I <sub>5110_2.5_AVDD</sub>			40 <sup>(6)</sup>	
• 3.3V digital supply <sup>(4)</sup>	I <sub>5110_3.3_VDD</sub>			50 <sup>(6)</sup>	
• 3.3V analog supply <sup>(5)</sup>	I <sub>5110_3.3_AVDD</sub>			150 <sup>(6)</sup>	
Supply Current @ CLK =135MHz (gm5120)	I <sub>5120</sub>		500		mA
• 2.5V digital supply <sup>(2)</sup>	I <sub>5120_2.5_VDD</sub>			500 <sup>(6)</sup>	
• 2.5V analog supply <sup>(3)</sup>	I <sub>5120_2.5_AVDD</sub>			50 <sup>(6)</sup>	
• 3.3V digital supply <sup>(4)</sup>	I <sub>5120_3.3_VDD</sub>			60 <sup>(6)</sup>	
• 3.3V analog supply <sup>(5)</sup>	I <sub>5120_3.3_AVDD</sub>			150 <sup>(6)</sup>	
Supply Current @ Low Power Mode*	I <sub>LP</sub>		50		mA
<b>INPUTS</b>					
High Voltage	V <sub>IH</sub>	2.0		V <sub>DD</sub>	V
Low Voltage	V <sub>IL</sub>	GND		0.8	V
Clock High Voltage	V <sub>IHC</sub>	2.4		V <sub>DD</sub>	V
Clock Low Voltage	V <sub>ILC</sub>	GND		0.4	V
High Current (V <sub>IN</sub> = 5.0 V)	I <sub>IH</sub>	-25		25	μA
Low Current (V <sub>IN</sub> = 0.8 V)	I <sub>IL</sub>	-25		25	μA
Capacitance (V <sub>IN</sub> = 2.4 V)	C <sub>IN</sub>			8	pF
<b>OUTPUTS</b>					
High Voltage (I <sub>OH</sub> = 7 mA)	V <sub>OH</sub>	2.4		V <sub>DD</sub>	V
Low Voltage (I <sub>OL</sub> = -7 mA)	V <sub>OL</sub>	GND		0.4	V
Tri-State Leakage Current	I <sub>OZ</sub>	-25		25	μA

**NOTE (1):** Low power figures result from setting the ADC, DVI, and clock power down bits so that only the micro-controller is running.

**NOTE (2):** Includes pins CVDD\_2.5, VDD1\_ADC\_2.5, VDD2\_ADC\_2.5, VDD\_RX0\_2.5, VDD\_RX1\_2.5 and VDD\_RX2\_2.5.

**NOTE (3):** Includes only VDD\_RXPLL\_2.5.

**NOTE (4):** Includes pins VDD\_DPLL, VDD\_SDDS, VDD\_DDDS and RVDD.

**NOTE (5):** Includes pins AVDD\_RED, AVDD\_GREEN, AVDD\_BLUE, AVDD\_IMB, AVDD\_RX0, AVDD\_RX1, AVDD\_RX2, AVDD\_RXC, AVDD\_RPLL, AVDD\_SDDS and AVDD\_DDDS.

**NOTE (6):** Maximum current figures are provided for the purposes of selecting an appropriate power supply circuit.

## 5.2 Preliminary AC Characteristics

The following targeted specifications have been derived by simulation.

All timing is measured to a 1.5V logic-switching threshold. The minimum and maximum operating conditions used were: T<sub>DIE</sub> = 0 to 125 °C, V<sub>dd</sub> = 2.35 to 2.65V, Process = best to worst, C<sub>L</sub> = 16pF for all outputs.

**Table 22. Maximum Speed of Operation**

Clock Domain	Max Speed of Operation
Main Input Clock (TCLK)	24 MHz (14.3MHz recommended)
DVI Differential Input Clock	165MHz
ADC Clock (ACLK)	162.5MHz
HCLK Host Interface Clock (6-wire protocol)	5 MHz
Input Format Measurement Clock (IFM_CLK)	50MHz (14.3MHz recommended)
Reference Clock (RCLK)	200MHz (200MHz recommended)
On-Chip Microcontroller Clock (OCM_CLK)	100 MHz
Display Clock (DCLK)	135 MHz

**Table 23. Display Timing and DCLK Adjustments**

DP_TIMING ->	Tap 0 (default)		Tap 1		Tap 2		Tap 3	
	Min (ns)	Max (ns)	Min (ns)	Max (ns)	Min (ns)	Max (ns)	Min (ns)	Max (ns)
Propagation delay from DCLK to DA*/DB*	1.0	4.5	0.5	3.5	-0.5	2.5	-1.5	1.5
Propagation delay from DCLK to DHS	1.0	4.5	0.5	3.5	-0.5	2.5	-1.5	1.5
Propagation delay from DCLK to DVS	0.5	4.5	0.0	3.5	-1.0	2.5	-2.0	1.5
Propagation delay from DCLK to DEN	1.0	4.5	0.5	3.5	-0.5	2.5	-1.5	1.5

Note: DCLK Clock Adjustments are the amount of additional delay that can be inserted in the DCLK path, in order to reduce the propagation delay between DCLK and its related signals.

**Table 24. 2-Wire Host Interface Port Timing**

Parameter	Symbol	MIN	TYP	MAX	Units
SCL HIGH time	T <sub>SHI</sub>	1.25			us
SCL LOW time	T <sub>SLO</sub>	1.25			us
SDA to SCL Setup	T <sub>SDIS</sub>	30			ns
SDA from SCL Hold	T <sub>SDIH</sub>	20			ns
Propagation delay from SCL to SDA	T <sub>SDO3</sub>	10		150	ns

Note: The above table assumes OCM\_CLK = R\_CLK / 2 = 100 MHz (default) (ie 10ns / clock)

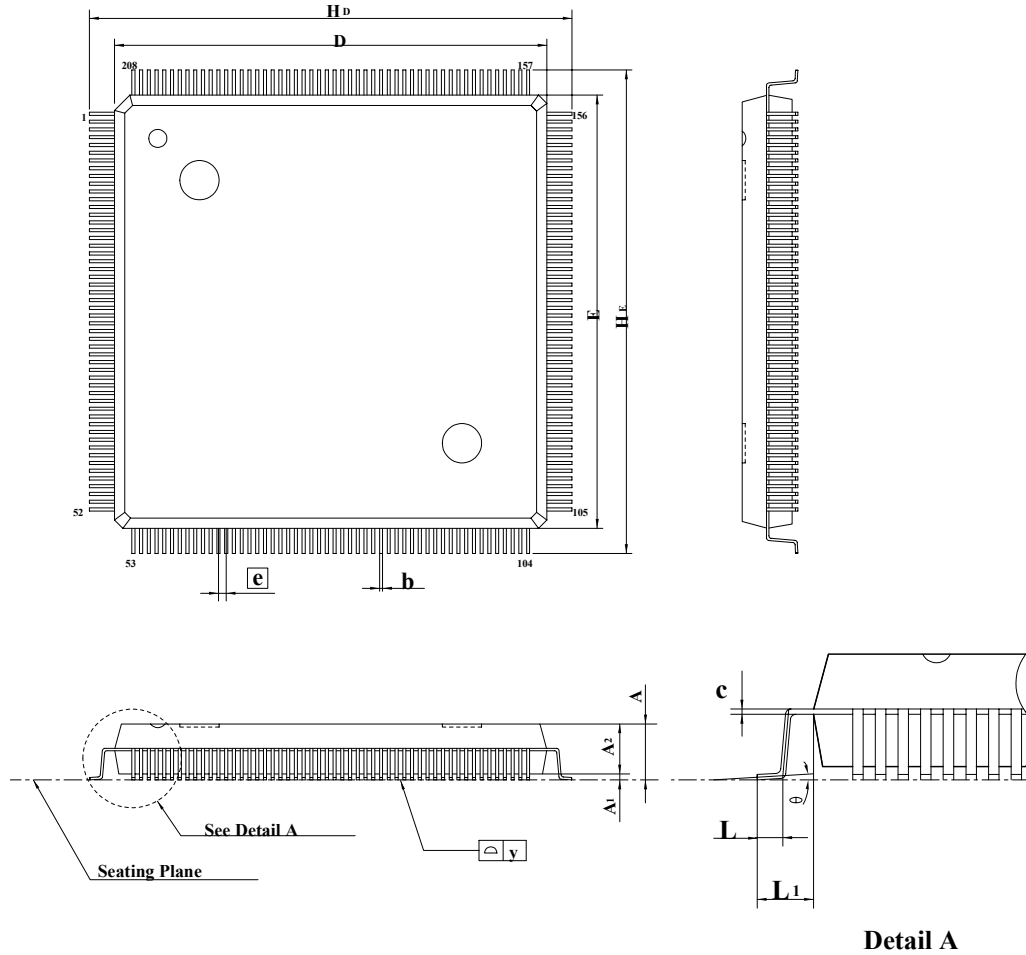
## 6. ORDERING INFORMATION

Order Code	Application	Package	Temperature Range
gm5110	XGA	208-pin PQFP	0-70°C
gm5110-H <sup>(1)</sup>	XGA	208-pin PQFP	0-70°C
gm5120	SXGA	208-pin PQFP	0-70°C
gm5120-H <sup>(1)</sup>	SXGA	208-pin PQFP	0-70°C

**Note (1):** gm5110-H and gm5120-H versions will only be sold to HDCP licensed customers.

## 7. MECHANICAL SPECIFICATIONS

**Figure 30. gm5110/gm5120 208-pin PQFP Mechanical Drawing**



Symbol	Dimension in mm		
	Min	Nom	Max
<b>A</b>	3.92	—	4.07
<b>A1</b>	0.25	—	—
<b>A2</b>	3.15	3.23	3.30
<b>b</b>	0.18	—	0.28
<b>c</b>	0.13	—	0.23
<b>D</b>	27.90	28.00	28.10
<b>E</b>	27.90	28.00	28.10
<b>[e]</b>	0.50 BSC		
<b>HD</b>	30.95	31.20	31.45
<b>HE</b>	30.95	31.20	31.45
<b>L</b>	0.65	0.80	0.95
<b>L1</b>	1.60 REF		
<b>y</b>	—	—	0.10
<b>θ</b>	0°	—	7°